



JOVIAL

JOVGF26

Foldable 3-Wheel Golf Push Cart

New Deluxe Scorecard Holder,
Upper & Lower Brackets with Strap

USER GUIDE

WARNING:

- For your own safety, please read and understand these warnings and keep this user guide for future reference.
- Always make sure the cart is fully extended and locked before use. Always make sure the cart is folded and locked properly before lifting or transporting.
- Do not run while using this product.
- Do not use accessories other than those designed for use with your cart.
- Keep all packing materials away from children and recycle where possible or where required by law.

MAINTENANCE

- To clean the trolley, wipe with a soft, dry cloth.
- Car polish may be used to maintain finish.
- Lubricate moving parts every 6 months.

WARNING:

- Keep hands and fingers away from moving or sliding parts!
- Always keep control of the Golf Push Cart -
Do not let it run down hills without full control.



PARTS LIST

- A** Handle
- B** Handle Tube
- C** Scorecard
- D** Slide Lock
- E** Upper Bracket
- F** Joint
- G** Right Weight Stabilize Rod
- G1** Left Weight Stabilize Rod
- H** 2 Holes Leg Frame
- H1** 3 Holes Leg Frame
- I** Rear Wheel Set
- J** Leg Bracket
- K** Right Wheel Lock Mechanism
- K1** Left Wheel Lock Mechanism
- L** Anti-Splay Wire
- M** Mainly Frame
- N** Lower Bracket
- P** Front Wheel Set

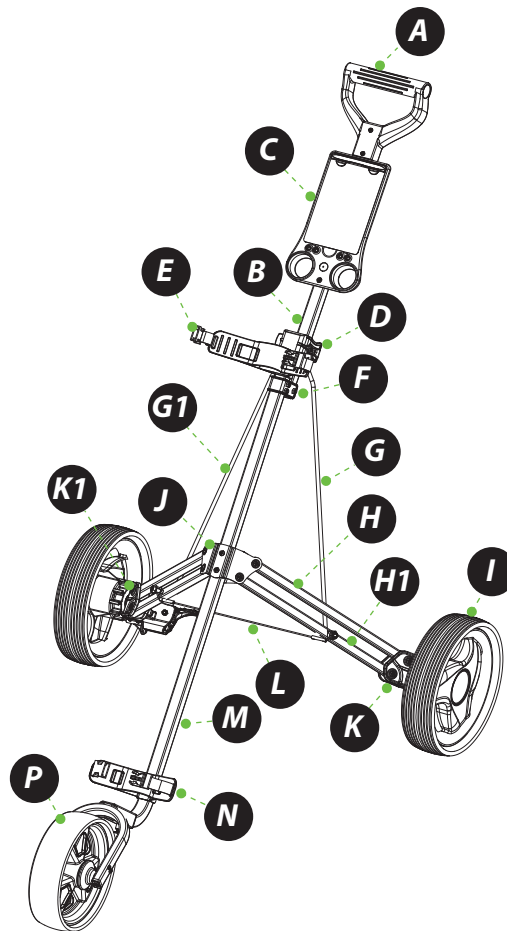

ASSEMBLY STEPS

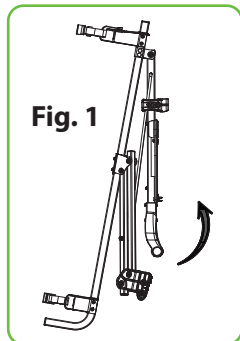

Lift the handle to level position as Fig. 1

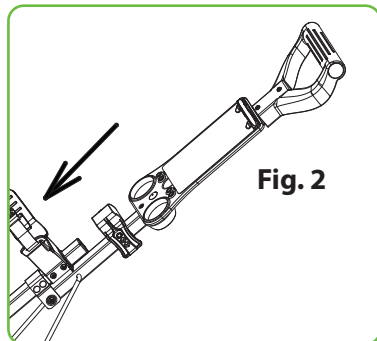

Move the slide lock downside and lock to upper bracket as Fig. 2

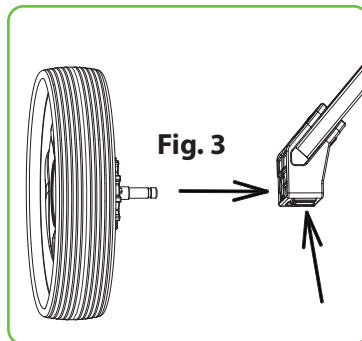

Press the button on the wheel holder to assemble the rear wheel as Fig.3.

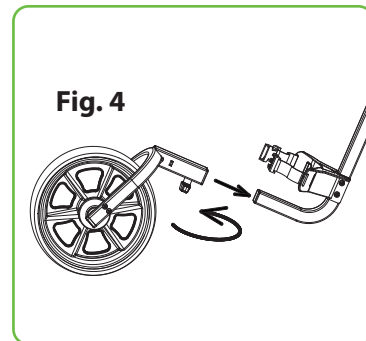

Snap front wheel insert mainly frame and then rotating the button tighten it as Fig.4.

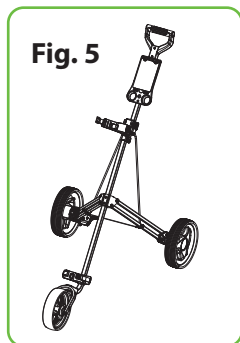

Completely unfolding and assembly as Fig. 5.

FOLDING STEPS

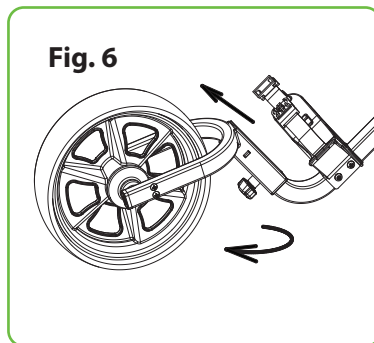

Through rotating the button to release the front wheel as Fig.6.

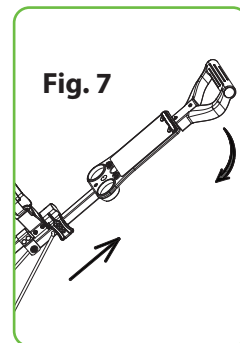

Move the slide lock toward up to release the handle as Fig.7.

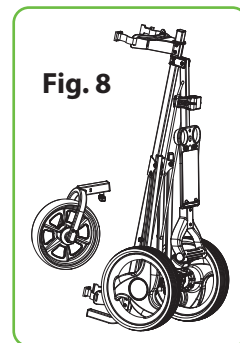
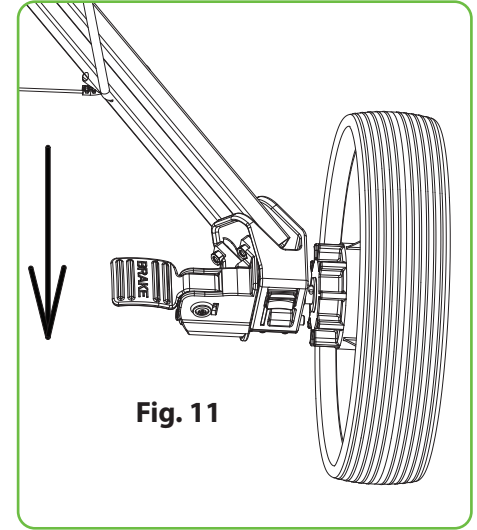
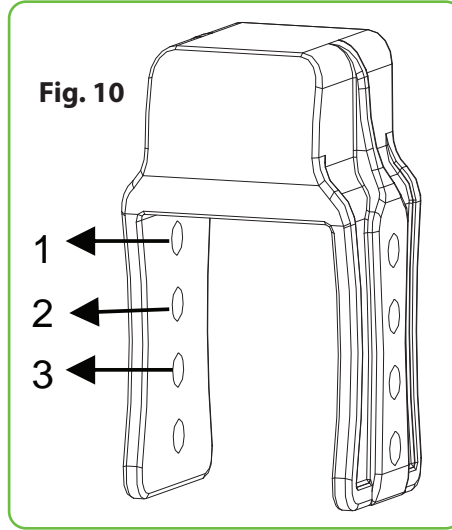
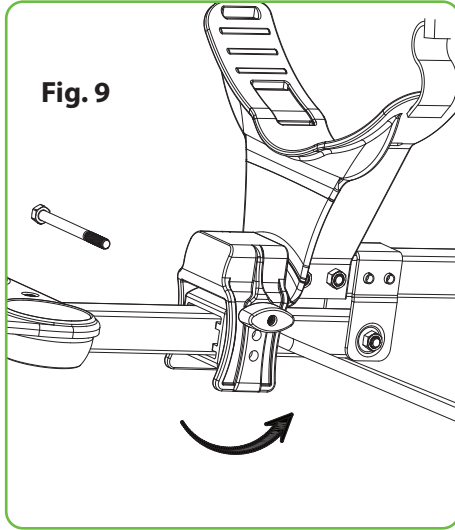

Fig. 8 shows the folded position.

ASSEMBLY DETAILS



Through adjusting the slide hole to adjust the handle height as Fig.9. and have 3 adjustable position as Fig.10. And for the upper bracket, it suits for the stand and normal bag as Fig.9.

Push on the brake pedal to stop the rear wheel and pull off to release as Fig.11.

FRONT WHEEL ADJUSTMENT MECHANISM

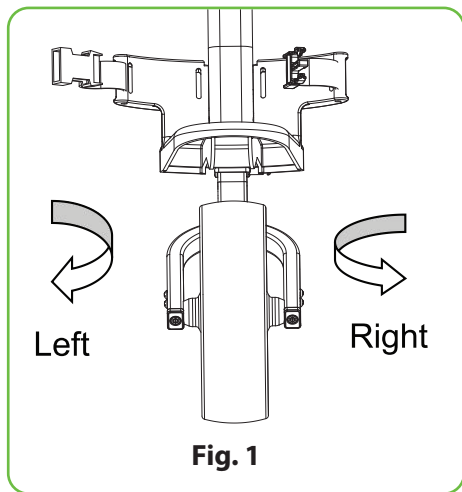

1. If during use, you find the cart veers to the right or left, please see the instructions below to correct this problem. (Fig.1)

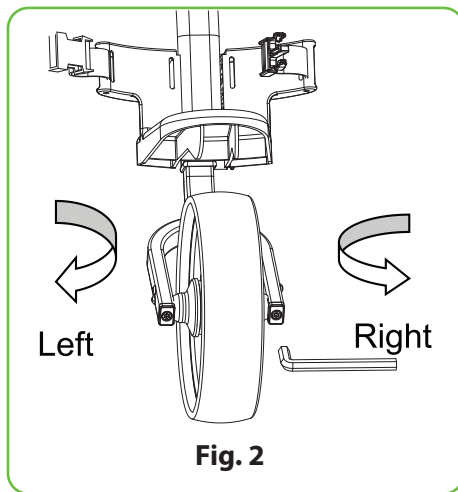

2. If the cart veers to the left, face the front wheel of the cart and use the Allen wrench provided to screw the right bolt counterclockwise or the left bolt clockwise until the front wheel is centered between the front fork. (Fig.2)

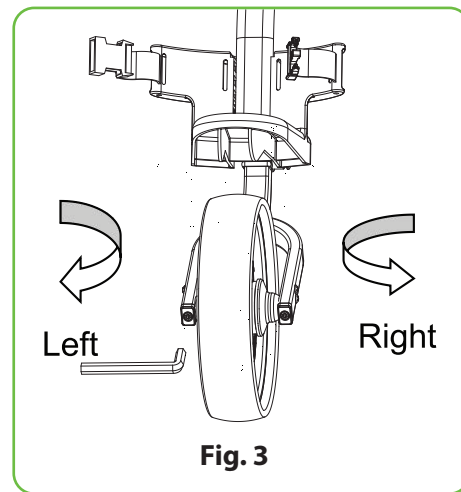

3. If the cart veers to the right, face the front wheel of the cart and use the Allen wrench provided to screw the left bolt counterclockwise or the right bolt clockwise until the front wheel is centered between the front fork. (Fig.3)

FEATURES:

- New Deluxe Scorecard Holder
- Upper and Lower Bracket with Strap
- Foam Handle Grip
- Ergonomic Padded Adjustable Handle
- Includes Scorecard Holder, and Patented Bag Holder
- Simple Quick Braking System
- Durable and Compact Size for Easy Storage and Transportation
- Easy to Fold and Unfold
- Designed for Multiple Pushing Positions

WHAT'S IN THE BOX:

- (1) 3-Wheel Golf Push Cart

TECHNICAL SPECS:

- Construction Material: Steel Frame
- Max. Load Capacity: 28.7 lbs.
- Front Wheel Size: 8 -inches
- Rear Wheels Size: 9.5" -inches
- Folded Product Dimension (L x W x H): 19.9" x 14" x 42.5"-inches
- Unfolded Product Dimension (L x W x H): 51.2" x 28" x 38.8" -inches

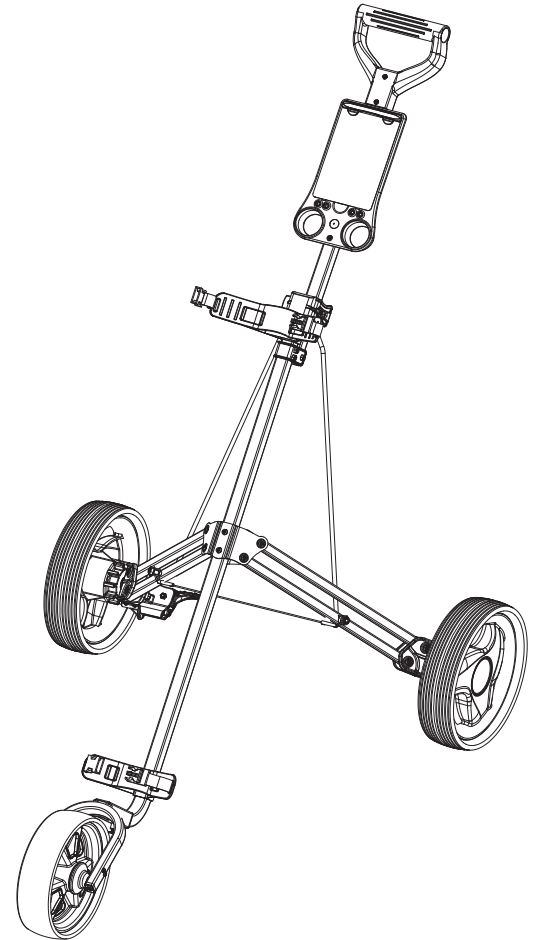



JOVIAL

Questions? Comments?

We are here to help!

Phone: (1) 718-535-1800

Email: support@pyleusa.com

