

nutr<sup>ic</sup>hef  
by **PYLE**



# PKTM15

2-in-1 Electric Glass Kettle & Tea Maker  
Tea Brewing Kettle, Water Boiler & Warmer

USER MANUAL

## KEY FIGURE DEFINITIONS

**Power-On:** Upon powering on, the display will show "----" indicating you're in standby mode. Press the key again to enter shutdown mode.

**Function:** In standby, after selecting a function (see below), the corresponding indicator light flashes. 5 seconds after the light, heating will start and the display will show the current water temperature. If the yogurt function is selected, then a countdown will be displayed instead.

**(BOIL FLOWER TEA YOGURT SOUP  
KEEP-WARM HEALTH TEA BOIL)**

*(No pot will display 'E1')*

**Timer key:** Press this key to adjust the time

**Temperature regulating key:** Press this key to adjust the temperature.

**Warning Tone:** Each press of a button, will produce a sound. When the selected the function is complete, there will be three consecutive sound reminders;

**Error Codes:**

'E1' — **Sensor Open or Pot needs to be placed**

'E2' — **Sensor Short**

'E3' — **Overheating**

**Pot missing:** Display will show 'E1' and heating will turn off after 30 seconds.

**Memory Function:** If the pot is removed and replaced within 30 seconds, the current function will continue.

**NOTE:** There will be a 3 second delay in order to prevent improper contact while adjusting placement.

**Excess Temperatures** over 248°F, will show 'E3' on the display. The unit will turn off the heating for safety so as not to impact the life of the product.

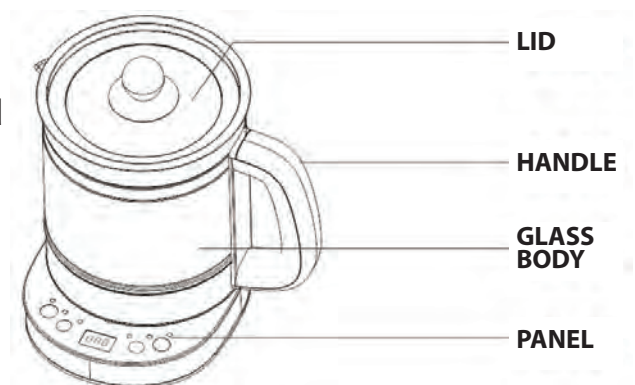
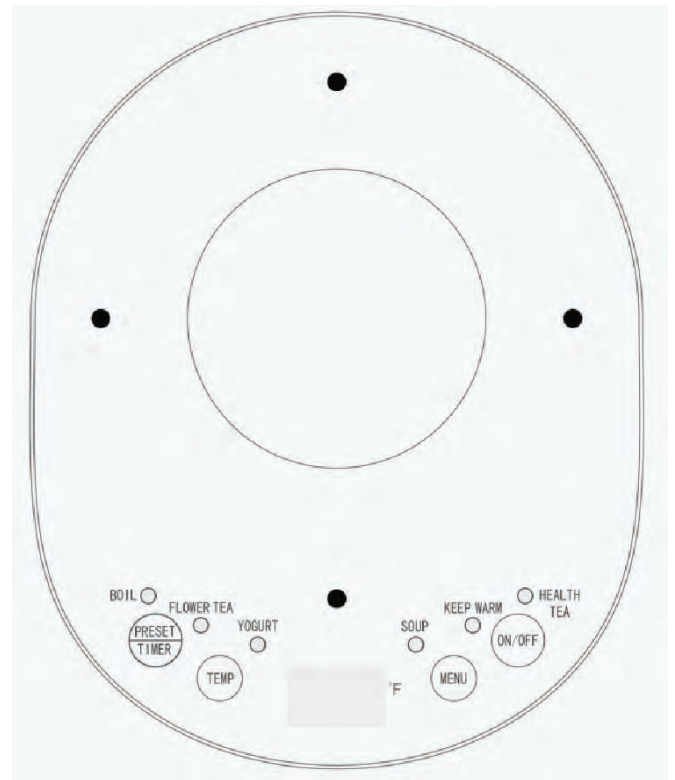

# FUNCTIONS

- 1. Boil:** Lights flash 5 seconds, after heating to boiling, reminder will sound, and then the power will cut off; the display will show the water temperature
- 2. Flower Tea:** Lights flash 5 seconds, then the unit enters the working state, began full power heated to boiling; then intermittent heating 5min, the temperature remains 206°F-212°F; after completion, the sound prompt goes off three times, then automatically enter the insulation program for 90 minutes.  
Default insulation temperature is 194°F; the temperature is displayed for 90 minutes after the end of the power-off
- 3. Yogurt:** Combine milk and yogurt with a proportion of 10:1 into the yogurt cup mix, mix evenly and cover. Press the "function" key to select "yogurt". The indicator light flashes for 5 seconds. At this time using the "timing" button, allows you to choose between a 4 to 15 hour cycle. The unit will automatically enter the working state, the display will show remaining time; and the unit will cycle heating to ensure that the temperature is maintained at 97°F-102°F. The default time for the function is 8 hours. After completion of the function, the unit will sound 3 times and power will be shut off.  
**NOTE:** Usually yogurt will be completed between 8 to 12 hours; the longer the time, the more thick the yogurt.
- 4. Soup:** Lights flash 5 seconds, automatically enters the working state, then the measured temperature will display. Full power heating will be applied until boiling; at which point an intermittent heating mode will activate for 30min where the temperature is maintained at 206°F~212°F; at the end of the allotted time, the unit automatically enters heat preservation for 90min, then powers off.  
**NOTE:** Pay attention to the water and make sure it does not exceed the maximum water level line to prevent soup from spilling over.
- 5. Keep Warm:** The default heat preservation temperature is '149 °F', and the default heat preservation time is 4 hours. The temperature and holding time can both be adjusted.  
**NOTE:** There's an insulation temperature deviation of 39 °F
- 6. Health Tea:** Lights flash 5 seconds, then full power heating until boiling; at which point the unit will immediately enter an intermittent heating mode where the temperature is maintained at 206 °F ~ 212 °F, for about 40 min (the default) to complete the process. After the completion of the process, sound will beep and the display will show the temperature.

FUNCTION	DEFAULT TIME	ADJUSTABLE TIME RANGE	AUTO-INSULATION	DEFAULT HOLDING TEMPERATURE	DEFAULT HOLDING TIME	ADJUSTABLE TEMPERATURE RANGE
Quick start heating			NO			
Flower Tea	5 Mins	1-30 Mins	YES	194 °F	90 Mins	
Yogurt	8 Hours	4-15 Hours	NO			
Soup	30 Min	20-99 Mins	YES	158 °F	90 Mins	
Keep Warm	4 Hours	1-12 Hours		149 °F		40-100 °F (Adjusted once every 9 °F)
Health Tea	40 Min	20-99 Mins	NO			

# nutrichef

by **PYLE**



**VISIT US ONLINE:**

*Have a question?*

*Need service or repair?*

*Want to leave a comment?*

[PyleUSA.com/ContactUs](http://PyleUSA.com/ContactUs)

**PYLE**