

**PYLE**  
PyleUSA.com



**VISIT US ONLINE:**  
Have a question?  
Need service or repair?  
Want to leave a comment?

[PyleUSA.com/ContactUs](http://PyleUSA.com/ContactUs)

**PYLE**

**Questions? Issues?**

We are here to help!

Phone: (1) 718-535-1800

Email: [support@pyleusa.com](mailto:support@pyleusa.com)



**PLMRSBA10**

Marine Grade Slim Active Subwoofer  
10" 900 Watts Low-Profile Active Amplified Marine  
and Waterproof Subwoofer System  
Suitable for Under-seat Installations

**User Manual**

## Introduction

With the **PLMRSBA10**, we are introducing a low-profile amplified subwoofer. Low enough to easily fit below the seat of your car. This system offers you a quick and easy way to add a high-powered subwoofer system to your audio system.

The integrated amplifier in the **PLMRSBA10** features low pass crossovers, and a control for adjusting the input sensitivity from 0.12V to 3.5V.

Both high level (speaker level) and low level (RCA type) inputs are present, making this a universal solution for use with any head unit or other input source.

For further flexibility in the use of a subwoofer, a variable bass boost control has been included. You can control the subwoofer level with the remote level control module.

## Mounting the Subwoofer

1. Find a suitable location in the vehicle in which to mount the amplifier.

A typical location is shown below:

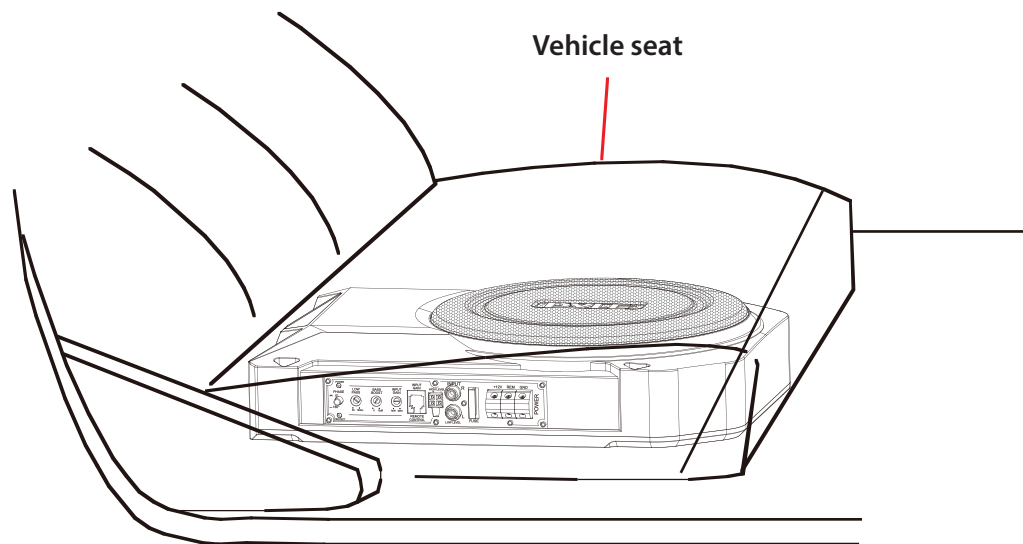

2. Make sure there is sufficient air circulation around the intended mounting location.

3. Mark the location for mounting hole screws by positioning the cabinet where you wish to install it. Make a small mark to identify the position and remove the unit. Thoroughly clean the area you plan to attach the subwoofer, using a vacuum cleaner and press down on it securely.

## Control Panel and Features

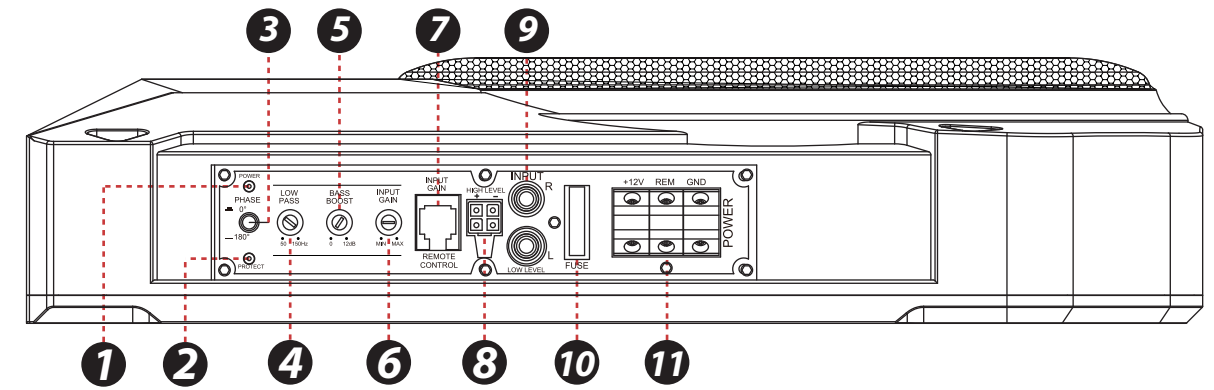

1. **POWER ON LED INDICATOR**

2. **PROTECT LED INDICATOR**

3. **PHASE SHIFT:** Use this switch to help compensate for time alignment problems in the system. Such problems usually result from having the subwoofer at a different distance from the listener than the other speakers in the system.

4. **LOW PASS FILTER:** This control permits you define the frequency range you want the subwoofer amplifier to receive. The subwoofer will reproduce all sound BELOW the frequency you set. If the rest of your system is weak on the mids, you may wish to set this control relatively high. If the midrange is well covered by the rest of your system, you will probably want the subwoofer to only receive lower frequency signal.

5. **BASS BOOST:** The bass boost feature will increase the sound level the bass frequencies.

6. **INPUT GAIN CONTROL:** After you have installed your system, turn this control to minimum. Turn the head unit on (and the subwoofer will turn on via the remote connection). Turn the head unit volume to about 2/3 full level. Slowly turn up the subwoofer input gain control until you hear a small amount of distortion. Then reduce the level until the distortion is completely gone. Leave the control at this setting.

7. **REMOTE LEVEL CONTROL PORT:** Attach the included remote level control to control the volume level of the subwoofer independently

8. **HIGH LEVEL (speaker level) INPUTS:** If your head unit does not have RCA outputs, you can use the speaker outputs for the audio source for the PLMRSBA10. Use the supplied cable and connect the outputs properly as shown in the connection diagram in this manual.

9. **LOW LEVEL RCA INPUTS:** Low level inputs are the recommended way to introduce the audio signal to the subwoofer if RCA outputs are present on your head unit or other signal source (such as a sound processor).

10. **FUSE:** The fuse is rated at 25A. Do not use a fuse with a different value and **NEVER** replace the fuse with a wire or coin.

11. **POWER TERMINALS**

### Low Level Input Wiring

Low-level (RCA) input wiring is preferred for best audio performance. Most trunk or hatchback installations will require a 15-20 foot RCA cable, while pickup trunks and under-seat installations will require a 6-12 foot RCA cable. Always use a high quality cable.

**NOTE:** Do not connect BOTH the high level and low level inputs from your receiver to your amplifier at the same time!

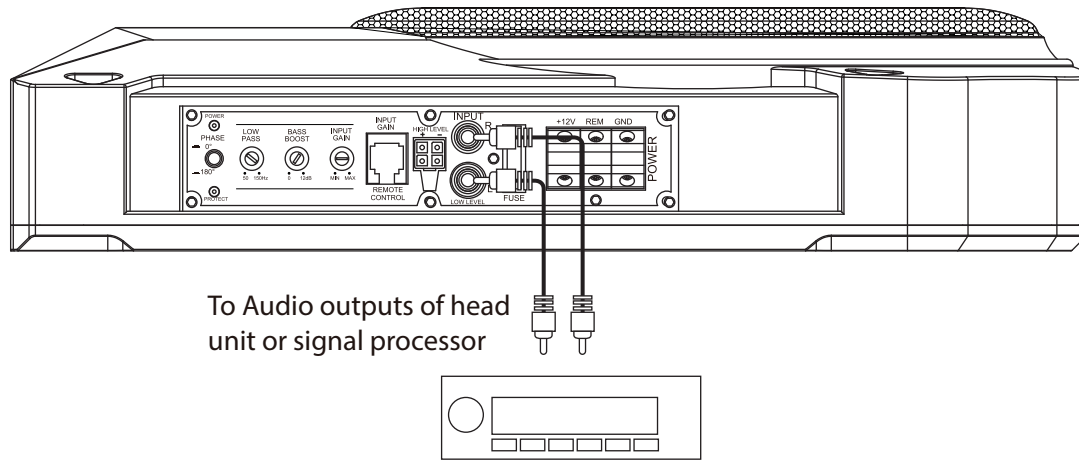

### High Level Input Wiring

The high level input(s) should only be used when your receiver lacks RCA outputs. If the RCA outputs are not present, connect the speaker outputs from the receiver to the high level input connector of the amplifier. Be sure to observe polarity to avoid audio phase problems.

**NOTE:** Do not connect BOTH the high level and low level inputs from your receiver to your amplifier at the same time!

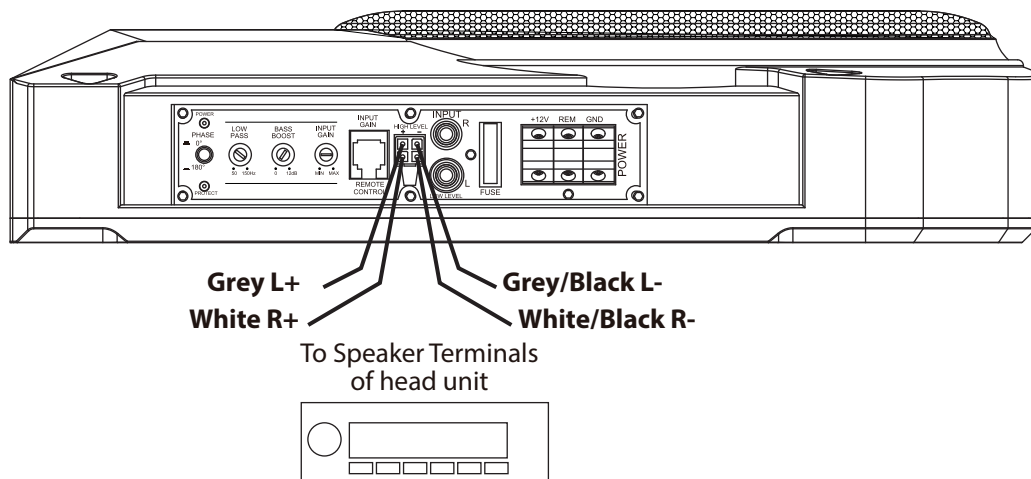

### Power Connections

Connect the ground terminal to the closest point on the chassis of the vehicle. Keep this ground wire to less than 39" (100 cm) in length. Use 8 gauge (or heavier) wire. Connect the remote terminal to the remote output of the head unit using 16 gauge (or heavier) wire. Connect an empty fuse holder within 18" (45 cm) of the car battery, and run 8 gauge (or heavier) cable from this fuse to the amplifier location. Then connect the fuse holder to the "BATT+" connection on the subwoofer rear panel.

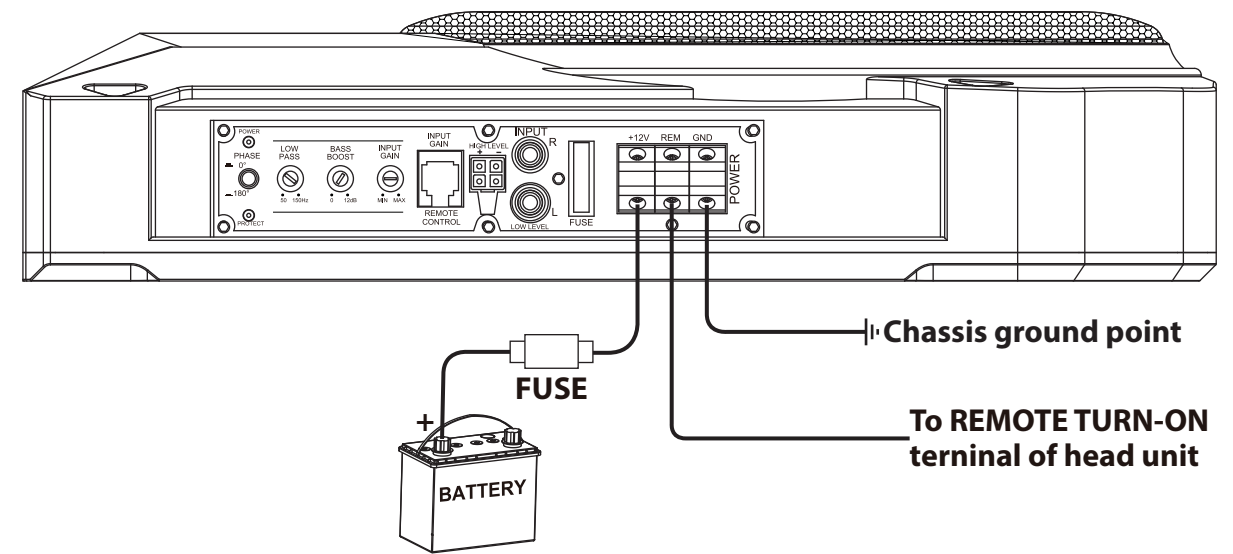

### Remote Level Control Connection

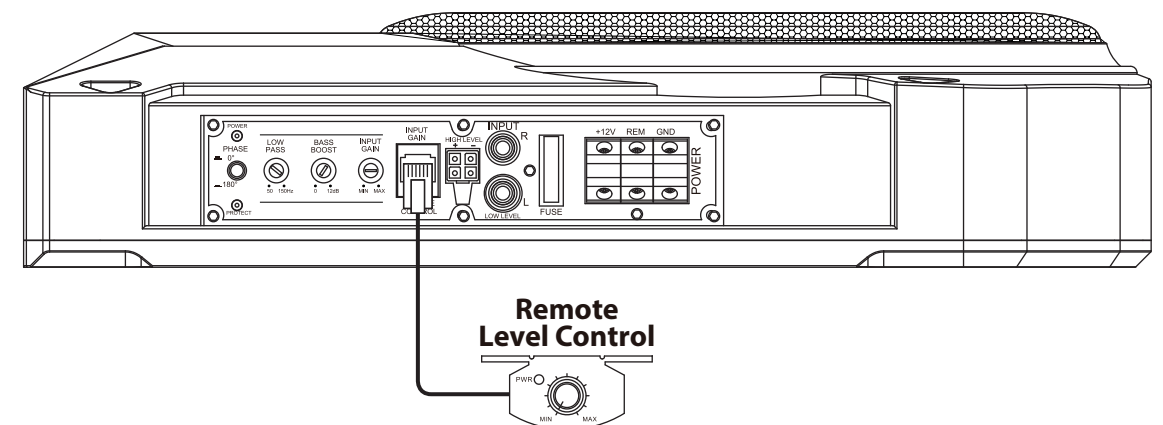

Install the remote control securely under the dash or in a similar location where using it will not distract the driver.

## Troubleshooting

If you experience operation or performance problems with this product, compare your installation with the electrical wiring diagram on the previous pages. If problems persist, read the following troubleshooting tips which may help eliminate the problems.

PROBLEM	POSSIBLE REASON	SOLUTION
<b>Not switching on. Power LED not 'on'</b>	NO +12v to power wire	Check fuses and connections to battery.
	NO power to remote wire	Check remote on connections to head unit.
	Fuse broken	Replace fuse with correct type and amperage.
<b>Not working, but status LED 'on'</b>	Fuse blown	Replace fuse with correct type and amperage.
	Amplifier too hot	Move unit to vented area. Turn head unit down.
<b>No sound</b>	Head Unit	Check head unit volume level.
	Gain control not set up	Ensure you have set up the amplifier gain level control
	Connections	Check all power, remote on and ground connections



This product can expose you to a chemical or group of chemicals, which may include "Di (2-ethylhexyl) phthalate (DEHP)" which is known in the state of California to cause cancer, birth defects, or other reproductive harm.

**WARNING:** For more info, go to <https://www.p65warnings.ca.gov/>.

## Features:

- 10" Slim Woofer
- Low-Level RCA Input
- High-Level Speaker Line Input
- Blue LED Power Status Indicator
- Red LED Protection Status Indicator
- Remote Bass Boost Level Control
- Delay Remote Turn-On Thermal
- Short and Overload Protection Circuits

## What's in the Box:

- Amplified Subwoofer
- Remote Subwoofer Level Control
- Remote Subwoofer Control Cable
- Hi-level Input Wire
- Mounting Hardware

## Technical Specs:

- Phase Shift Switch: 0 or 180°
- Adjustable Input Sensitivity: 0.12V-3.5V
- 0 to +12dB Variable Bass Boost (@50Hz)
- Low Pass Filter (50-150 Hz)
- Fuse: 1x25A
- Max Power: 900 watt
- RMS Power: Amplifier: 100Watt
- Slim woofer: 150Watt
- Product Dimension: 14.2" x 11.2" x 3" -inches

