

Table of contents

Safety Instructions.....	1
Introduction.....	4
Features.....	4
Shipping contents.....	8
Projector exterior view.....	9
Controls and functions.....	10
Positioning your projector.....	15
Choosing a location.....	15
Obtaining a preferred screen size.....	16
Connection.....	22
Connecting video source devices.....	22
Connecting an HDMI device.....	24
Connecting a Component-Video source device.....	26
Connecting an S-video or a Composite Video source device.....	27
Connecting a computer.....	29
Connecting ATSC TV.....	31
Using the projector.....	32
Starting up.....	32
Switching input signal.....	32
Adjusting the projected image.....	33
Optimizing the image.....	35
Turning the power off.....	37
MENUS.....	38
Using the menus.....	38
Picture menu.....	40

Img. Adj menu.....	41
Setup menu.....	42
Audio menu.....	43
Maintenance.....	46
Care of the projector.....	46
Cleaning the lens.....	46
Storing the projector.....	47
Transporting the projector.....	47
Specifications.....	48

Safety Instructions

Your projector is a high-tech product, designed and tested to meet the latest standards for safety. However, to ensure safe use of this product, it is important that you follow the instructions mentioned in this manual.

1. Please read this manual carefully before operating the projector.

Keep this manual handy for future reference.

2. Always place the projector on a horizontal surface during operation.

- Do not place the projector on an unstable cart, stand, or table as it may fall and be damaged;
- Do not place inflammables near the projector;
- Do not use if tilted at an angle of more than 10 degrees left to right, nor at angle of more than 12 degrees front to back.

3. When you think service or repair is required, take the projector only to a suitably qualified technician.

4. Do not place the projector in any of the following environments:

- locations where temperatures may become excessively high, such as the inside of a car with all windows closed;
- locations where excessive humidity, dust, or cigarette smoke may contaminate optical components, shortening the projector's lifespan and darkening the screen;
- locations near fire alarms;
- locations with an ambient temperature above 40°C/104°F.

- locations where altitude is higher than 3050 meters / 10000 feet above sea level.
5. Do not block the ventilation holes while the projector is on (even in standby mode):
 - Do not cover the projector with any item;
 - Do not place the projector on a blanket, bedding or any other soft surface.
 6. Do not step on the projector or place any objects upon it. Do not place liquids near or on the projector. Liquids spilled into the projector will make damages to the projector. If the projector does become wet, go to your seller or authorized service center for help.
 7. Do not look straight into the projector lens during operation. It may harm your sight.
 8. Do not attempt to disassemble this projector yourself, which will void your warranty. There is no user serviceable part inside the projector. Refer servicing only to suitably qualified professional service personnel.
 9. In areas where the mains power supply voltage may fluctuate by 10 volts, it is recommended that you connect your projector through a power stabilizer, surge protector or uninterruptible power supply (UPS) as appropriate to your situation.
 10. When you won't use the projector for a prolonged period of time, or want to take it to another place, please use the supplied packing materials to store the projector.
 11. Do not store the projector on end vertically. Doing so may cause the

projector to fall over, causing injury or resulting in damage.

12. This projector is capable of displaying inverted images for ceiling mount installation. Use only the suggested ceiling mount to mount it.

Introduction

Features

Stunning LED projector, Your Daily Displayer!

Conventional projectors have always been for office use, commercial presentations, and rarely, for those top end home theater users.

None of these has been designed for your daily digital life.

Now, a new kind of projector is coming,

with powerful media functions and revolutionary LED technology,

to highlight your digital world.

More than cost effective, Ultra-long lamp life

Conventional filament bulb lamps offer you just 2000~3000 hours lamp life;

HID lamp for single LCD projector, 6000 hours' life;

LED lamp, offer you a semi-permanent life, 20,000 hours' life; with the lamp, you can...well basically do anything you'd ever want to.

Environment Friendly, and energy saving

The use of the ultra bright LED light source, compared to the conventional halogen lamps used by other projectors, not only reduces the amount of waste in replacing burnt out bulbs, but actually means the projector uses up to 75% less energy, making it not only environmentally sound, but cheaper to run. Even so, there is function

making it possible to switch the working state between Normal and Economic modes to achieve an unbelievably higher energy saving.

Instant On/Off

You will never again waste precious time waiting for the lamp to warm up after turning on the projector. Then we will be ready to go before your X360 has even booted. And when the match is over and you are declared the victor. You can just turn off and head out, without having to go through that irritating “Cooling Period” before you can cut the power.

Cooler and Quieter

The light engine of this projector is super efficient. Compared to conventional projectors, it runs at a mere fraction of the temperature, thus doing away with the need for big cooling fans, which is good, unless you like the noise of whining motors over the top of your movies.

All our projectors have a noise as low as 28 dB due to Unique patented cooling system.

HD Ready

Due to the latest image-processing MCU, which has super quality upscale capacity, and higher native resolution LCD panel used in the projectors, all our projectors can offer you an HD Ready image.

Therefore, you can connect this projector to blu-ray disc players, PS3, etc, to enjoy the best video programs you may find.

Music2FM

The audio of the sources is turned into FM signals. This signal can be received with your FM radios, such as amplifiers with FM receivers, mobiles phones with FM radio function, and so on.

This Music2FM, is specially adopted for better enjoyment. Though it is not the latest technology, but firstly adopted by Home Theater Projectors. With this function, you can easily enjoy the wonderful TV games or watching TV without disturbing the people around you. Moreover, sitting in an environment without other surrounding noise, makes you feel the True Home Theater.

Note: *Music2FM may not be available due to local laws.*

2 years/20'000 hours standard warranty

The standard warranty for projector and lamp is 2 years.

When it comes to projector lamp warranties, most manufacturers fall short—offering you just only 2,000 hours or 6 months warranty. As one of the leading LED projector manufacturers, we believe users should enjoy stress-free watching for much longer. That is why we introduce the manufacturer's warranty.

At 2 years/20,000 hours, it's maybe the most extensive warranty in the world to come standard over an entire range of projectors.

Note: *20,000 hours/2 years, by rule of which comes first.*

LED ENGINE

Patented high efficiency LED optical engine, can make full use of the

light from the LED lamps, this is the reason that we can find the balance between low power consumption and high brightness. Other LED projectors, even by big players, are not genuinely usable. But this model is times brighter than those conceptual LED projectors. Even in a well-lit room, this model can throw approximately a 60' image that is clearly readable, with colors that aren't washed out.

Patented optical engine, dust free

Due to patented technologies, this LED projector uses full-sealed structure inner design, which means that you are void to clean the filters of the projector time by time, which is necessary for other projectors.

5 glasses lens with 80% offset

Traditional Chinese projectors, no matter HID projector or other LED projector, can not offer you offset function, which means you have to put the projector in a higher place, or ceiling mount it in a lower position, otherwise you can not see the whole screen. This LED projector offers you 80% offset function, with which you can much more easily display.

Shipping contents

Standard accessories

Some of the accessories may vary from region to region, and may differ from those illustrated.

Projector

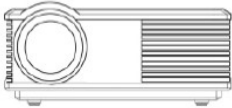

Remote control



Power cable



User manual



Warranty card



Ceiling Mount screws



Optional accessories

1.HDMI Cable

2 Component Video cable

3.VGA cable

4.Earphone

5.Ceiling mount

6.Projection screen

Projector exterior view

Front and upper side

- 1.Lens
- 2.LOGO and model number
- 3.IR sensor
- 4.Key pad
- 5.Vent(heated air outlet)
- 6.Speaker window

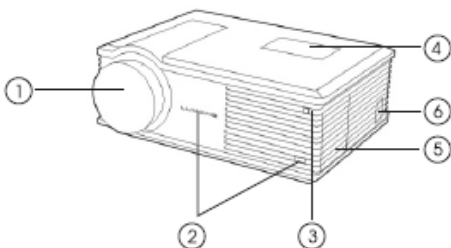

Rear side

- 7.Input sockets
- 8.Power socket
- 9.Factory label

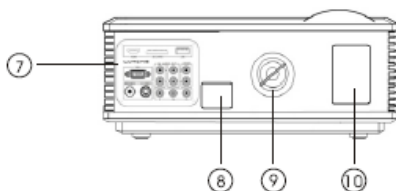

Right side

- 10.Vent(cool air inlet)
- 11.Speaker window

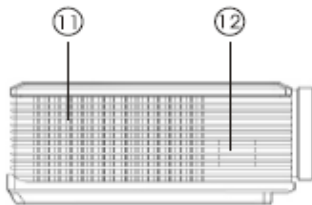

Under side

12. Projector information

13. Caution

14. Serial number

15. Adjusting feet

16. Ceiling mount feet

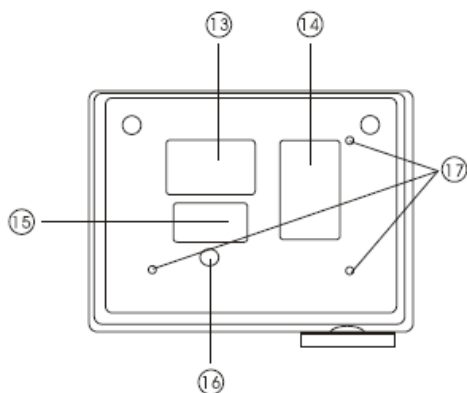

Controls and functions

Projector

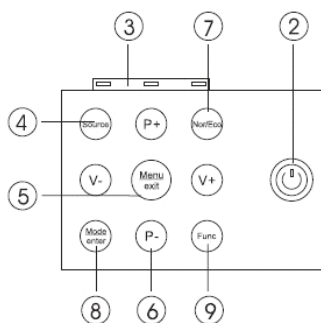
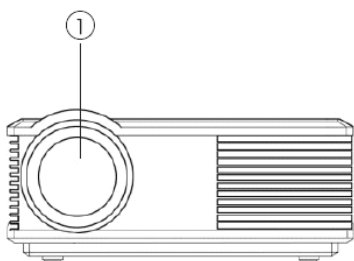

1. Focus adjustment

Adjust the focus of the projected image. See "Choosing the image size and sharpening the clarity" on Page 33 for details.

2. POWER

Turn the projector on or off. See Pages 32 and 37 for details.

3.Index lamp

Lights up or flashes when the projector is operating.

4.Source button

Sequentially selects the input signal from ATSC-TV, CVBS, S-VIDEO, YUV,HDMI1, HDMI2, and PC. See "Switching input signal" on Page 32 for details.

5.MENU button

Toggle the On-Screen Display (OSD) menu on and off. It is also used to exit the submenu. See "Using the menus" on Page 38 for details.

6.V+, V-, P+, P- buttons

When the On-Screen Display (OSD) menu is activated, the buttons are used as directional arrows to select the desired menu items and to make adjustments. See "Using the menus" on Page 38 for details. V+/V- is also used to turn up/down the volume, and P+/P- to change the TV channels.

7.Nor/Eco button

Reserved button.

8.Mode/enter button

Press this button to change the picture mode.

9.Func button

Use this button to trigger the Musci2FM function. See Page 6 for details.

Remote control

There are different remote controls used for different models with different functions. Please check which remote control your projector is using before operations.

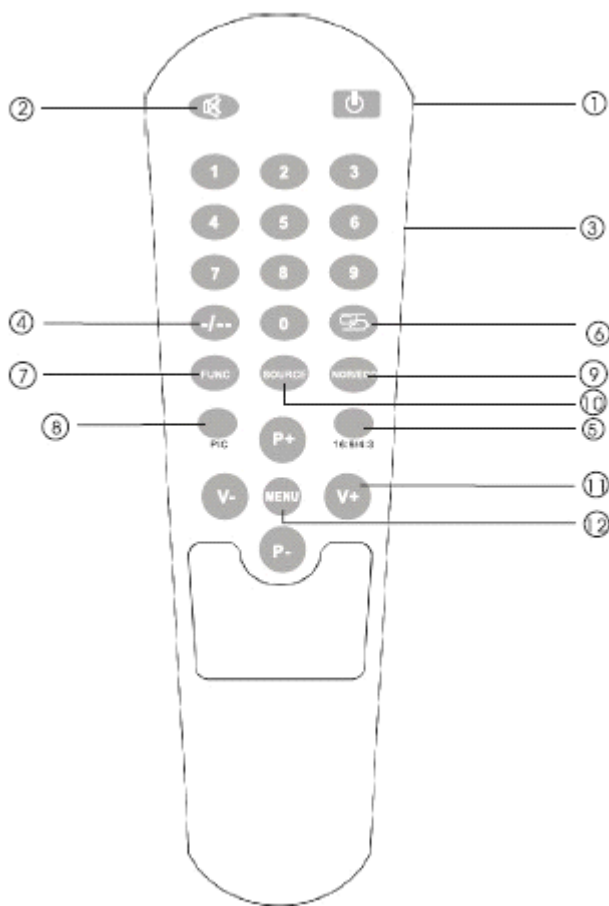

1. POWER

Turn the projector on or off. See Pages 32 and 37 for details.

2. Mute

Turn on or off the volume.

3. Numeric key

On TV source, press these keys to change TV channels.

4.

Use the key to choose the TV channels for short.

5. 16:9/4:3

Use this button to change the screen size. See “Zooming the projection size” on Page 21 for details.

6.

Return to the last channel

7. FUNC

Reserved key for Music2FM or other functions.

8. SOURCE

Press this button to select the input signal that you want

9. Nor/Eco

Press this button to allow your projector work in Normal or Economy

mode.

Note that some models are in high brightness and low noise mode, so there would be no change when you press this button.

10.Source

Sequentially selects the input signal from ATSC TV, PC, AV, S-VIDEO, HDMI1, HDMI2, and Y/Pb/Pr. See "Switching input signal" on Page 33 for details.

11.P+/P- and V+/V-

When the main menu is activated, the buttons are used as directional arrows to select the desired menu items and to make adjustments.

See "Using the menus" on Page 38 for details.

12..MENU

Toggle the On-Screen Display (OSD) menu on and off. It is also used to exit the submenu. See "Using the menus" on Page 38 for details.

Positioning your projector

Choosing a location

Your projector is designed to be installed in one of four possible installation locations:

- 1.Floor in front of screen;
- 2.Ceiling in front of screen;
- 3.Floor at rear of screen; or

4. Ceiling at rear of screen.

Your room layout or personal preference will dictate which installation location you select. Take into consideration the size and position of your screen, the location of a suitable power outlet, as well as the location and distance between the projector and the rest of your equipment.

1. Floor front:

Select this location with the projector placed near the floor in front of the screen. This is the most common way to position the projector for quick setup and portability.

2. Ceiling front:

Select this location with the projector suspended from the ceiling in front of the screen. Purchase the suggested ceiling mount from your dealer to mount your projector on the ceiling.

Set Ceiling Front in the Setup > PRPJECTION menu after you turn the projector on.

3. Floor rear:

Select this location with the projector placed near the floor behind the screen. Note that a special rear projection screen is required.

Set Floor Rear in the Setup > PROJECTION menu after you turn the projector on.

4. Ceiling rear:

Select this location with the projector suspended from the ceiling behind the screen. Note that a special rear projection screen and the

suggested Ceiling Mounting are required for this installation location.

Set Ceiling Rear in the Setup > PROJECTION menu after you turn the projector on.

Note:

There are four screws for ceiling mount in the accessories bag, which are specially supplied for this projector. See “Shipping contents” on Page 8 for details.

Obtaining a preferred screen size

The distance from the projector to the screen, the zoom setting, and the video format each factors in the projected image size. We have provided separate tables of dimensions for both 16:9 and 4:3 screen ratios to assist you in determining the ideal location for your projector.

The projector should always be placed horizontally level (like flat on a table), and positioned directly perpendicular (90 right-angle square) to the horizontal center of the screen. This prevents image distortion caused by angled projections (or projecting onto angled surfaces).

If the projector is mounted on a ceiling, it must be mounted upside-down so that it projects at a slightly downward angle.

This projector has the function of zoom. See “Zooming the projection size” on Page 21 for details.

How to determine the position of the projector for a given screen size

1. Determine the aspect ratio of your screen, 16:9 or 4:3?

2.Refer to the table and find the closest match to your screen size in the left columns labeled “Screen Dimensions”. Using this value, look across this row to the right to find the corresponding projection distance.

For example, if you are using a 108-inch, 16:9-aspect-ratio screen, please refer to “16:9 (widescreen) ratio screen dimension table” on Page 19. The projection distance is 3.48m.

How to determine the recommended screen size for a given distance

This method can be used for situations where you have purchased this projector and would like to know what screen size will fit in your room.

The maximum screen size is limited by the physical space available in your room.

- 1.Determine the aspect ratio of your screen, 16:9 or 4:3?
- 2.Measure the distance between the projector and where you want to position the screen. This is the projection distance.
- 3.Refer to the table and find the closest match to your measurement in the projection distance column.
- 4.Using this value, look across that row to the left to find the corresponding screen diagonal listed in that row. That is the projected image size of the projector at that projection distance.

For example, if you have a 16:9-aspect-ratio screen and your measured projection distance is 3.5m, please refer to “16:9 (widescreen) ratio screen dimension table” on Page 19. The closest

match in the “projection distance” column is 3.48m. Looking across this row shows that a 108-inch screen is required. As your real projection distance is a little more than that of 108-inch screen, then the real projection screen size is a little more than 108 inches.

Installation for a 16:9 ratio screen

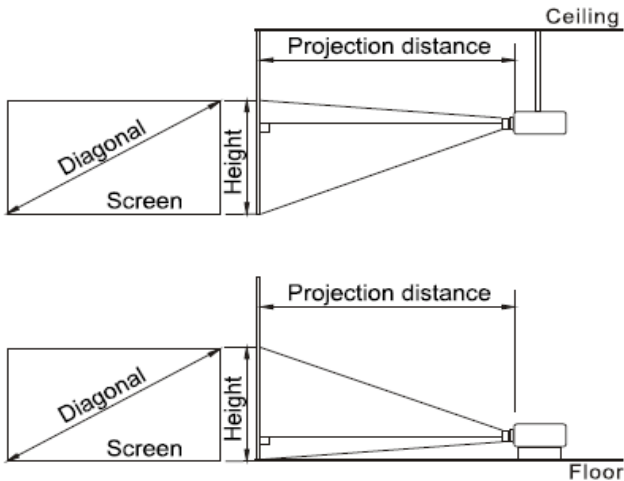

16:9 (widescreen) ratio screen dimension table

Screen Dimensions				Projection distance
Diagonal		Width	Height	From projector to screen
Inches	m	m	m	M
54	1.50	1.20	0.67	1.74
65	1.81	1.45	0.81	2.09
77	2.15	1.72	0.97	2.48
90	2.50	2.00	1.12	2.90

108	3.00	2.40	1.35	3.48
-----	------	------	------	------

Installation for a 4:3 ratio screen

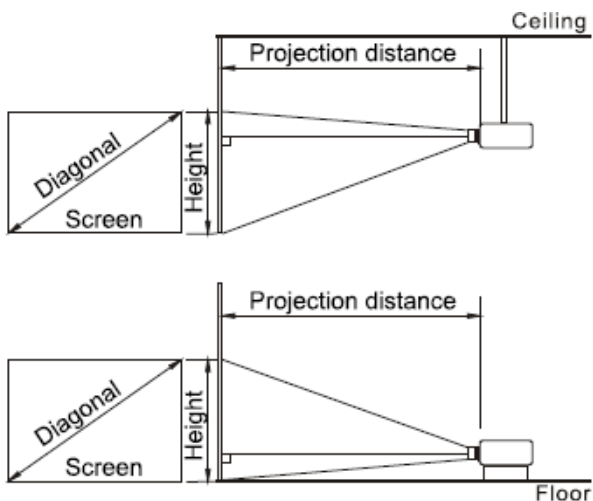

4:3 (standard) ratio screen dimension table

Screen Dimensions				Projection distance
Diagonal		Width	Height	From projector to screen
Inches	m	m	m	M
60	1.52	1.22	0.91	2.94
72	1.83	1.46	1.10	3.52
84	2.13	1.71	1.28	4.11
100	2.54	2.03	1.52	4.90
120	3.05	2.44	1.83	5.88

There is 3% tolerance among these numbers in the above two tables due to optical component variations. We recommend that if you intend

to permanently install the projector, you should physically test the projection size and distance using the actual projector for trial before you permanently install it, so as to make allowance for this projector's optical characteristics. This will help you determine the exact mounting position so that it best suits your installation location.

Zooming the projection size

This projector provides the zoom function to adjust your projection size when the projector is fitted but the projection size is a little bigger than the screen.

Set Zoom in the Img. Adj > V keystone menu after you turn the projector on. Or use the 16:9/4:3 button on the remote control.

Connection

You can connect the projector to any type of video equipment, such as a VCR, DVD player, digital tuner, cable or satellite decoder, video game console or digital camera. You can also connect it to a desktop or laptop PC.(Some of the functions may not be available according to your projector model.)

The projector can be connected to multiple video equipment at the same time by using different cables. All you need to do is to select the appropriate input source for the projector to display.

When connecting a signal source to the projector, be sure to:

- 1.Turn off all equipments before making any connections.
- 2.Use only the qualified correct type cables for each source with proper type plugs.
- 3.Ensure that all cable plugs are firmly fitted to the equipment sockets.

Note that all cables mentioned below may not be supplied with the projector (See Page 8 for the shipping contents). Most cables are commercially available from electronics stores. We recommend that you purchase international standard cables for cable connection.

Connecting video source devices

You can connect your projector to various video source devices that

provide any one of the following output sockets:

- HDMI
- Component Video
- S-Video
- Video (composite)

You need only connect the projector to a Video source device using just one of the above connecting methods, however each provides a different level of video quality. The method you choose will most likely depend upon the availability of matching terminals on both the projector and the Video source device as described below:

Best video quality

The best available video connection method is HDMI. HDMI (High-Definition Multimedia Interface) supports uncompressed video data transmission between compatible devices like DTV tuners, DVD players and displays over a single cable. It provides pure digital viewing and listening experience.

See "Connecting an HDMI device" on Page 24 for how to connect the projector to an HDMI device.

If no HDMI source is available, the next best video signal is Component Video (not to be confused with composite Video). Digital TV tuner and DVD players output Component Video natively, so if available on your devices, this should be your connection method of choice in preference to (composite) Video.

See "Connecting a Component-Video source device" on Page 26 for

how to connect the projector to a component video device.

Better video quality

The S-Video method provides a better quality analog video than standard composite Video. If you have both composite Video and S-Video output terminals on your video source device, you should select to use the S-Video option.

Least video quality

Composite Video is an analog video and will result in an acceptable, but less than optimal result from your projector, being the least video quality of the available methods described here.

See "Connecting an S-video or a composite Video source device" on Page 27 for how to connect the projector to an S-Video or composite Video device.

Note: *Composite Video shown on OSD is "AV".*

Connecting an HDMI device

Examine your video source device to see whether it has an HDMI socket available:

- If so, you can continue with this procedure.
- If not, you will need to reassess which method you can use to connect to the device.

To connect the projector to a HDMI device:

1. Take an HDMI cable and connect one end to the HDMI output socket of the Video source device.
2. Connect the other end of the HDMI cable to the HDMI input socket on the projector.
3. Connect one end of separate audio cable to the projector, and the other end to a suitable audio amplifier.

Note: *You can also connect the separate audio cable to a suitable audio amplifier. But the quality of the audio from HDMI is better.*

The final connection path should be like that shown in the following diagram:

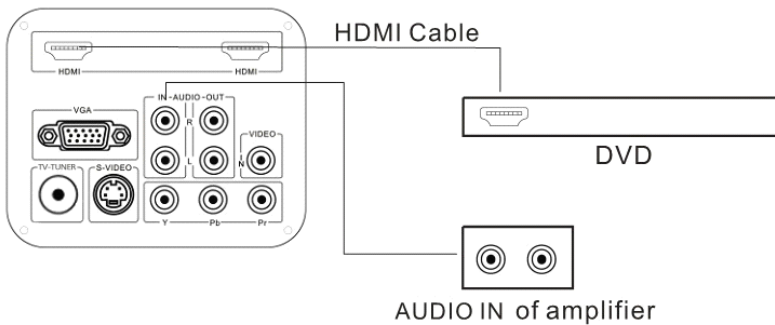

Note:

- *It is not recommended to establish the connection via a DVI to HDMI cable. The weight of the DVI to HDMI adapter may be pulling down on the HDMI port, causing it to become loose over time.*
- *If the selected video image is not displayed after the projector is*

turned on and the correct video source has been selected, please check that the video source device is turned on and operating correctly. Also check that the signal cables have been connected correctly.

- *Normally speaking, the HDMI source includes the video and audio contents. But in some circumstance, the audio can be separately output to the amplifier.*

Connecting a Component-Video source device

Check your Video source device to see whether it has a set of Component Video output sockets available:

- If so, you can continue with this procedure.
- If not, you will need to reassess which method you can use to connect to the device.

To connect the projector to a Component Video source device:

1. Take a Component Video cable and connect one end to the Component Video output sockets of the Video source device. Match the color of the plugs to the color of the sockets; green to green, blue to blue, and red to red.
2. Connect the other end of the Component Video cable to the COMPONENT sockets on the projector. Match the color of the plugs to the color of the sockets; green to green, blue to blue, and red to red.
3. You should also connect the separate audio cable to a suitable audio amplifier.

The final connection path should be like that shown in the following diagram:

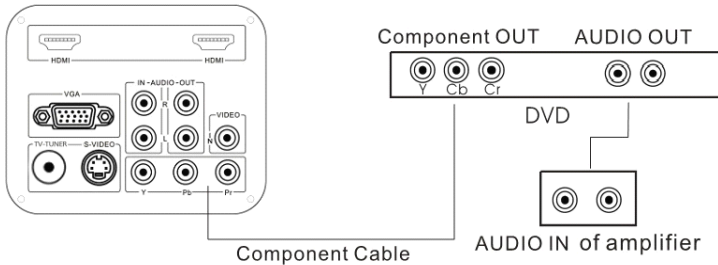

Note: *If the selected video image is not displayed after the projector is turned on and the correct video source has been selected, please check that whether the video source device is turned on and operating correctly. Also check that whether the signal cables have been connected correctly.*

Component Video is also called YUV.

Connecting an S-video or a Composite Video source device

Examine your Video source device to see if it has an S-Video or Composite Video output socket available:

- If so, you can continue with this procedure.
- If not, you will need to reassess which method you can use to connect to the device.

If you have already made a Component Video connection between the projector and the video source device, you need not connect to this

device again using an S-video or Composite Video connection as this makes an unnecessary second connection of poorer picture quality. You need only connect using a composite Video connection if neither Component Video nor S-video is supplied on the video source device (for example, with some analog video cameras). If S-video connectivity is available, you should use it in preference to composite Video.

See "Connecting Video source devices" on Page 22 for details.

To connect the projector to an S-video or a Composite Video source device:

With an S-video cable:	With a Video cable:
<ol style="list-style-type: none"> 1. Take an S-Video cable and connect one end to the S-Video output socket of the Video source device. 2. Connect the other end of the S-Video cable to the S-VIDEO socket on the projector. 	<ol style="list-style-type: none"> 1. Take a Video cable and connect one end to the Video output socket of the Video source device. 2. Connect the other end of the Video cable to the VIDEO socket on the projector.
<ol style="list-style-type: none"> 3. You should also connect the separate audio cable to a suitable audio amplifier. 	

The final connection path should be like that shown in the following diagram:

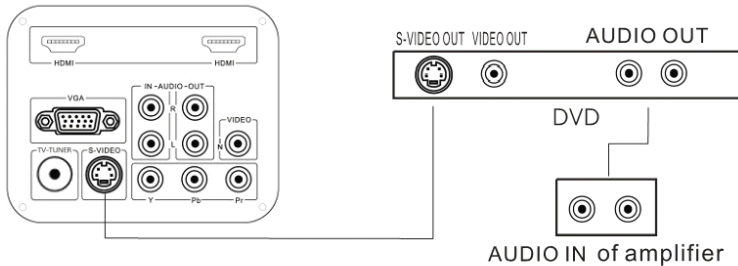

Note:

- *Do not connect both S-video and Composite Video cables from the same video source device at the same time. You should only connect one or the other. See "Connecting Video source devices" on Page 22 for details.*
- *If the selected video image is not displayed after the projector is turned on and the correct video source has been selected, please check that whether the video source device is turned on and operating correctly. Also check that the signal cables have been connected correctly.*

Connecting a computer

The projector provides a VGA input socket that allows you to connect it to a laptop or desktop computer.

To connect the projector to a laptop or desktop computer

1. Take a VGA cable and connect one end to the D-Sub output socket of the computer.

2. Connect the other end of the VGA cable to the D-Sub signal input socket on the projector.

3. You should also connect the separate audio cable to a suitable audio amplifier.

The final connection path should be like that shown in the following diagram:

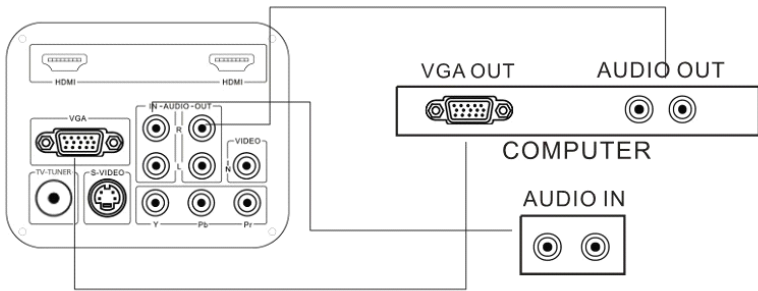

Note:

Many laptops do not turn on their external video ports when connected to a projector. Usually a key combination like Fn + F3 or CRT/LCD key turns the external display on/off. Locate a function key labeled CRT/LCD or a function key with a monitor symbol on the laptop. Press Fn and the labeled function key simultaneously. Refer to your laptop's documentation to discover your laptop's key combination.

To set the resolution of the computer to be WXGA will get the best image.

Connecting American ATSC TV

The projector provides a built-in TV tuner that allows you to connect it to ATSC TV.

To connect the projector to ATSC TV

1. Take a TV cable and connect one end to the output socket of the TV source.
2. Connect the other end of the TV cable to the TV signal input socket on the projector.
3. You can also connect the audio cable from Audio Out sockets to a suitable audio amplifier.

Using the projector

Starting up

- 1.Plug the power cable into the projector and into a wall socket. Turn on the wall socket switch (where fitted) and the power switch on the projector. Check that the Power indicator on the projector lights red after power has been applied.
- 2.Press the  POWER button on the projector or remote control to turn the projector on. The projector will be started up immediately.
- 3.Switch on the connected equipment.
- 4.Press the SOURCE button on the projector or remote control to choose the input source you want. See "Switching input signal" on Page 32 for details.

Note:

If the frequency/resolution of the input signal exceeds the projector's operating range, it will not operate normally. Please change to an input signal which is compatible with the projector's resolution or set the input signal to a lower setting.

Switching input signal

The projector can be connected to multiple equipment at the same time. However, it can only display one at a time.

Press the SOURCE button repeatedly on the projector or remote control, then the input source will be changing as the following:

ATSC TV —CVBS—S-VIDEO—YUV—HDMI1—HDMI2—PC

Adjusting the projected image

Adjusting the projection angle

Place the projector on a surface level, move the projector to be in the center of the screen and make it perpendicular to the screen, with the top and bottom edge of the projection image parallel to the screen.

There are two adjuster feet on the bottom of the projector. These can be used if necessary to change the projection angle. Screw the feet in or out as appropriate to aim and level the projection angle.

Note:

- *Please do place the projector on a surface level firstly, otherwise the projection image will be unadjustable.*
- *If the screen and the projector are not perpendicular to each other, the projected image becomes vertical trapezoidal, which can not be adjusted by this projector. Please adjust the projector again to make it perpendicular to the screen.*

Choosing the image size and sharpening the clarity

1. Change the projection distance to get the projection size that you need according to the screen dimension table on Page 19 and 20 for reference.

2. Then sharpen the image by turning the lens.



Note:

- *When you turn the lens to sharpen the image, the image size will be changed a little. You can move the projector forward or backward slightly to get the optimal image size.*

Correcting keystone

Keystoning occurs when the projector is not perpendicular to the screen and is where the projected image displays visible as a trapezoid shape like the following:

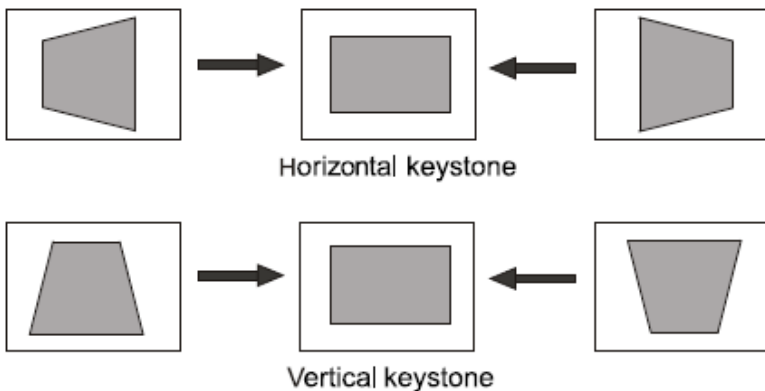

To correct the image's shape, you can perform the following steps.

1. For the horizontal keystone, you can move the projector to be perpendicular to the screen.
2. For the vertical keystone, use the V keystone function in the Img. Adj menu.

Note:

- *Please do not put the projector at a surface place when operating.*
- *Only vertical keystone can be corrected here, and the optimal angles are within ± 40 degrees.*

Optimizing the image

To optimize the image, use the remote control or key panel on the projector to operate on-screen menus. For the operation of on-screen menus, please refer to "Using the menus" on Page 38.

The following steps are optional. You do not need to follow every step. It depends on the image you desire.

Adjusting picture quality

You can adjust Brightness, Contrast, Sharpness, Color, Tilt and Color Temperature settings using the Picture submenus.

- All settings in the Picture menu will take effect right away.
- Some picture adjustments are available only when certain input ports are in use. Unavailable adjustments are shown blank on the screen.

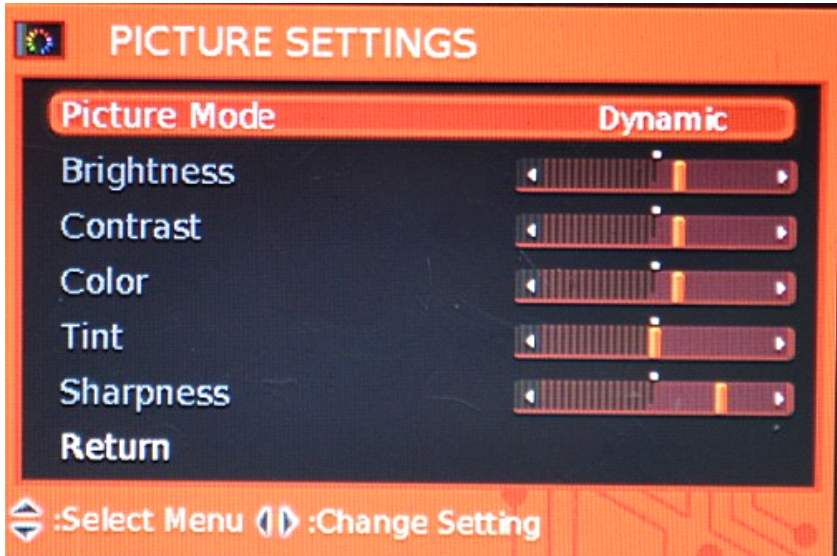

Selecting the aspect ratio

The "aspect ratio" is the ratio of the image width to the image height. Most analog TV signals and computers are in 4:3 ratio and DVDs are usually in 16:9 ratio.

With the advent of digital signal processing, digital display devices like this projector can dynamically stretch and scale the image output to a different aspect than that of the image input source. Images can be stretched in a linear manner so the whole of the image is stretched equally, or non-linearly, which distorts the image.

You can change the projected image ratio (according to your source signal) by using the Img Adj > Image size OSD menu. Select an aspect ratio to suit the format of the video signal and your display

requirements.

Note:

- *You can use the Zoom button on the remote control to change the aspect ratio.*
- *The native aspect ratio of the LCD panel is 16:10.*

Turning the power off

1. Press the POWER button on the projector or remote control for two seconds, then the projector will be shut off.
2. The Power indicator light flashes green, the lamps shut down, and the fans continue to run for a few seconds to cool down the projector.

As the projector uses LED lamps as light source, you can turn it on again in a few seconds.

3. The Power indicator light is a steady red once the cooling process has finished and fans stop.
4. Turn off the switch of the projector, and disconnect the power cord from the wall socket.

MENUS

Using the menus

The projector is equipped with on-screen display (OSD) menus for making various adjustments and settings.

1. Press MENU on the projector or remote control to turn on the OSD .The first pop on menu is PICTURE.

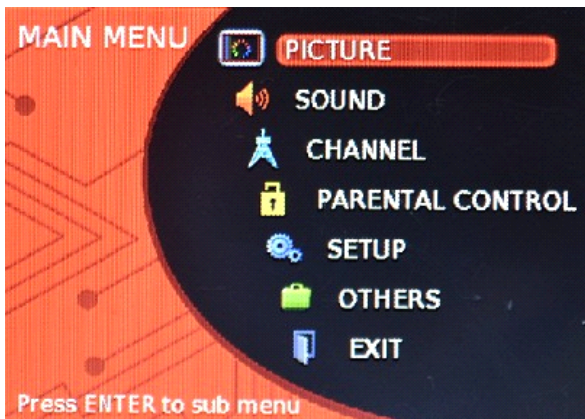

2. Press the V+ button to select the second menu "Img. Adj", or go on with the third menu...

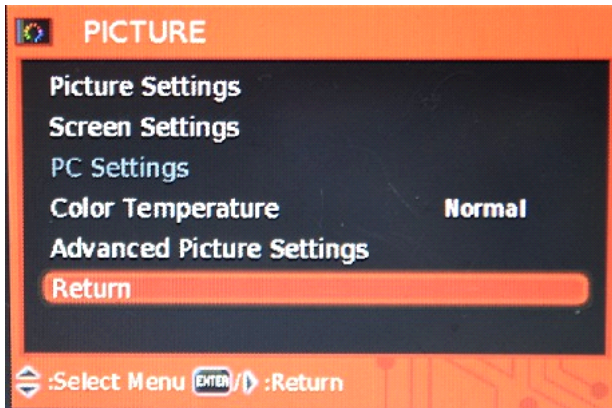

3. Press P- button to select the submenu, and then press the V+ button to choose the item you want.

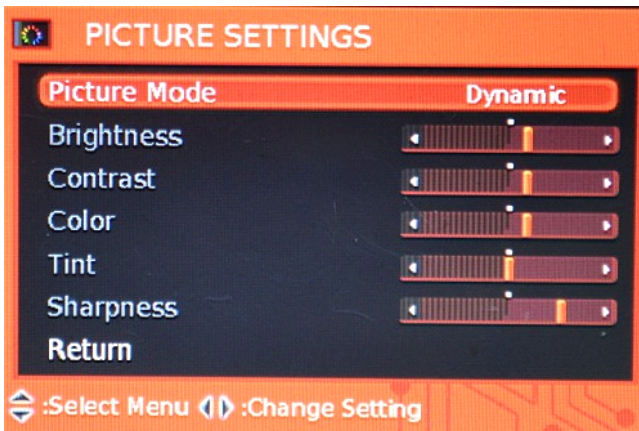

4. Press MENU on the projector or remote control to save and exit.



Picture menu

The Picture menu allows you to adjust the details of the projected image quality. You can change the parameters.

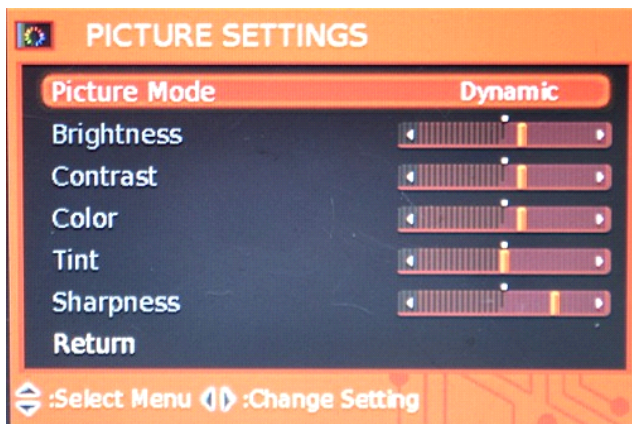

Picture Mode	Dynamic
Brightness	Adjust the brightness of the image. The higher the value, the brighter the image. And the lower the value, the darker the image. Adjust this control so the black areas of the image appear as black and that detail in the dark areas is visible.
Contrast	Adjust the degree of difference between dark and light in the image. The higher the value, the greater the contrast.
Sharpness	Adjust the picture sharpness. The higher the value, the sharper the picture.
Color	Change the colors of the image.
Tilt	Adjusts the color tones of the image. The higher the value, the more greenish the picture becomes. The lower the value, the more purplish the picture becomes.
Return	Exit

Img. Adj menu

The Image Adjustment menu allows you to adjust the image size, change the OSD menu place.



Function	Description
Screen Size	Choose the aspect ratio of the screen and zoom the screen size.
H position	Change the horizontal position of the OSD.
V position	Change the vertical position of the OSD.
Up to Down	Change the up to down of the OSD.
Left to Right	Change the left to right of the OSD.
Return	Exit

Setup menu

This menu allows you to choose the projection method, change the OSD language, set the sleep time and make some OSD changes.

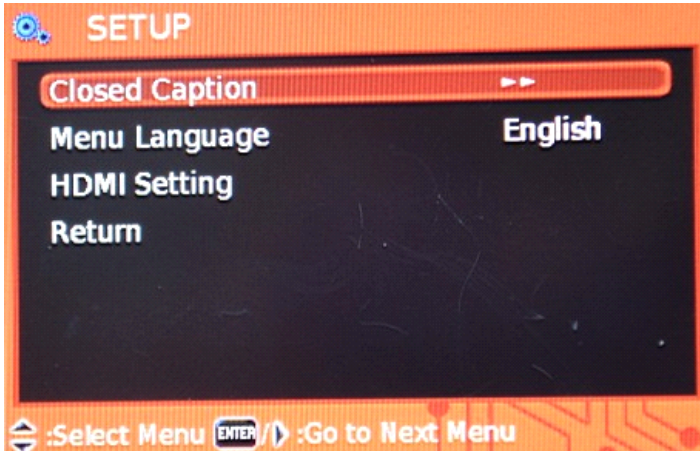

Closed Caption	Subtitle
Menu Language	Choose the OSD language.
HDMI Setting	Set HDMI for the projector.
Return	Exit

Audio menu

The Audio menu allows you to adjust the sound of the built-in speakers.

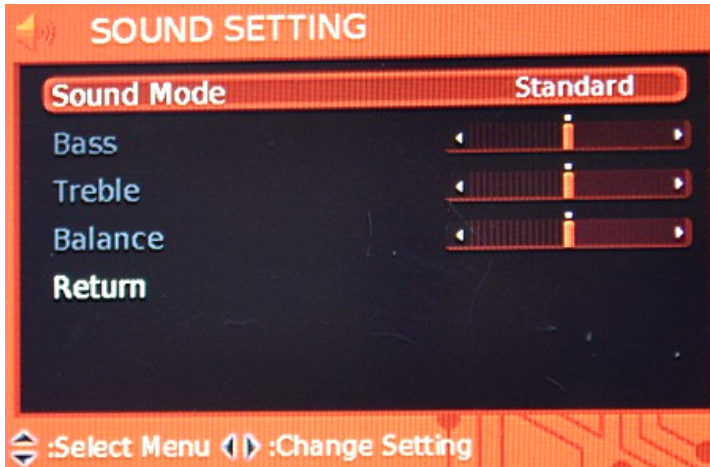

Note:

You can use V- and V+ on the remote control to change the volume for shortcut.

Maintenance

Care of the projector

Your projector needs little maintenance. The only thing you have to do on a regular basis is keep the lens clean and clean or replace the air filter. Never remove any parts of the projector except the air filter.

Contact your dealer or local authorized Customer Service Centre if the projector fails to operate as expected.

Cleaning the lens

Clean the lens whenever you notice dirt or dust on the surface. Before you attempt to clean the lens, turn the projector off, unplug the power cable, and leave it several minutes to cool completely.

1. Use the lens cleaning paper to remove dust.
2. If there is stubborn dirt or smudge marks, use a proper photographic lens brush or moisten a clean soft lens cloth with lens cleaner to gently wipe the lens surface.

Warning:

Never touch the lens with your finger or rub the lens with abrasive materials. Even paper towels can damage the lens coating. Only ever use a proper photographic lens brush, cloth, and cleaning solution. Do not attempt to clean the lens whilst the projector is switched on or is still hot from previous use.

Storing the projector

If you need to store the projector for an extended time, please:

1. Make sure the temperature and humidity of the storage area are within the recommended range for the projector. Please refer to the Specification page in this manual or consult your dealer about the range.
2. Retract the adjuster feet.
3. Remove the batteries from the remote control.
4. Pack the projector in its original packing or equivalent.

Transporting the projector

It is recommended that you ship the projector with its original packing or equivalent. When you carry the projector yourself, please use a soft carry case.

Specifications

Projection System	
LED+Single LCD Technology	LED+Single LCD Technology
Basic information	
Native Resolution	800x 600
Rescaled Resolution	480P, 576i/P, 720i/p, 1080i/p, SVGA, XGA, WXGA
Contrast Ratio	2000:1
Aspect Ratio	16:9/4:3
High Definition	HD compatible
Optical Engine	Dust-proof Optical engine
Projection lens	
Type	Digital zoom and manual focus
Material	All glass, 5 pieces
F-number	2.2
Focal Length	190mm
Zoom Ratio	Digital zoom 1.0-1.35
Screen size	60"-120"
Lamp	
Lamp type	LED
Lamp Lifespan	20,000 hours
Supported Signals	
Video	ATSC

Computer	WXGA / XGA / SVGA / VGA
Inputs	
HDMI	2 x HDMI
Component Video	3 x RCA (YUV)
Composite Video	1 x RCA
S-Video	1 x S-Video
Computer	1 x RGB
Audio	2 x RCA
TV Set	
Built-in TV Tuner	HD American ATSC TV
Output	
Audio	2 x RCA
Image and sound adjustments	
Keystone Correction	±40 degrees
Others	
Weight	3 Kgs
Dimensions	330*260*127(mm)
Noise	28 dB

USER'S MANUAL



WWW.PYLEAUDIOD.COM
MODEL:PRJ3D99TU



Printed in P.R.C.
Accessory Item code: Ls101240283H0D0

