



powered by webOS TV

PTVWEB32HHD - PTVWEB43UHD

USER GUIDE

Note: Keep this document for operation and performance reference.
Please visit us online for further reference and detailed product specifications.

CONTENTS

GENERAL SAFETY	3
GENERAL SAFETY INSTRUCTIONS	4
INSTALLATION	6
CONTROLS AND CONNECTIONS	7
REMOTE CONTROL	9
MENUS	10
FAQS	21
SPECIFICATIONS	22

ENVIRONMENT FRIENDLY DISPOSAL

You can help protect the environment!

CORRECT DISPOSAL OF THIS PRODUCT

To prevent possible harm to the environment or health from uncontrolled waste disposal, do not throw away the product with the normal household waste at the end of its life, but hand it in at an official collection point for recycling.



If at any time in the future you should need to dispose of this product please note that:
Waste electrical products should not be disposed of with household waste.
Please recycle where facilities exist. Check with your Local Authority or retailer for recycling advice. (Waste Electrical and Electronic Equipment Directive)

GENERAL SAFETY

Read this manual thoroughly before you start using the TV.

Store this manual, the completed warranty card, your receipt and the product packaging.

The safety precautions instructions reduces the risk of fire, electric shock and injury when correctly complied to.

Please follow all instructions and take notice of all warnings.



The lightning flash with symbol within the triangle is intended to warn you of a non-insulated dangerous voltage in the product's enclosure that could be of sufficient magnitude to generate a risk of electric shock to persons.



The exclamation point within the triangle is intended to warn you to the presence of important operating and maintenance instructions in the documents included with the product.

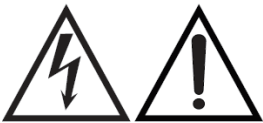

The cover (or back) of the unit should not be removed to prevent risk of electric shock.

This unit must be serviced by a qualified service personnel only.



IMPORTANT INFORMATION

The lightning flash symbol within the triangle is intended to warn you of non-insulated dangerous voltage the product's enclosure that could be of sufficient magnitude to generate a risk of electric shock to persons.

- Using Cabinets or stands recommended by the manufacturer of the television.
- Only using furniture that can safely support the Products.
- Ensure the Product is not overhanging the edge of the supporting furniture.
- Do not place the product on a high furniture without securing both the furniture and the product to a stable support.
- Do not place the product on cloth or other conductive materials.
- Warn children of the dangers of climbing on furniture to reach the television or its controls and to call for an adult to assist.
- Do not expose this appliance to rain or moisture as it may result in fire or an electric shock hazard
- Do not temper or change or modify the product in any way.
- Only use Accessories outlined and recommended by the manufacturer.
- Please do not expose the product to splashing or water contact
- Please do not place any object on top of the product including objects filled with liquids such as vases.
- Danger of explosion if battery is incorrectly placed. Replace with same or equivalent type.

GENERAL SAFETY INSTRUCTIONS

Please follow instruction when installing this product in accordance with the instruction manual. This product must be positioned in a sufficiently stable location, it can be potentially hazardous due to falling and can cause injury, particularly to children if it positioned incorrectly.

- Before installing this TV set, make sure your outlet voltage corresponds to the voltage stated on the product rating label.
- Do not use a damaged power cord, plug or loose outlet. Doing so may cause an electric shock.
- Do not plug several devices into the same outlet. Doing so may cause the outlet to overheat and start a fire. Make sure the outlet is readily accessible during operation of the equipment.
- Do not bend, twist or kink the power cord excessively.
- Do not allow anything to rest on or roll over the power cord and antenna cable. Doing so may cause a fire or an electric shock.
- Do not run the power cord near heat-producing appliances such as radiators, stoves or irons. The excessive heat could melt the insulation and expose live wires, resulting in fire or electric shock.
- Unplug this TV during lightning storms or when unused for long periods of time. Not doing so may result in fire or electric shock.
- Do not cover the ventilation openings of the product with items such as newspapers, tablecloths, curtains etc. or insert objects into the slots available on the products. As this could result in the product temperature rising and could cause a fire.
- If you notice any unusual odors or smoke around the unit, immediately disconnect the unit from the outlet and contact the service center. Failure to do so may result in fire or electric shock.
- When not using the unit for long periods of time or when you are moving the unit please ensure to disconnect the power cord from the wall socket.
- Please beware that dust could accumulate over time on the unit and cause it to generate heat and or deteriorate insulation, which in turn may result in an electrical fire.
- The product is not intended for use by persons (including children) with reduced physical, sensory or mental capabilities, or young children of any age. They must be supervised product by a person responsible for their safety.
- Batteries from the remote control must be only removed by an adult, the adult must ensure to keep them out of reach of infants and children. Seek medical attention immediately if a child has swallowed a battery.
- Batteries (battery pack or batteries installed) shall not be exposed to excessive heat such as sunshine, fire or the like.
- To maintain the product do not use any chemical or cleaning agent or wet cloth, please only ensure to utilize a dry cloth to wipe it down from marks or dust and only after unplugging the product from the power socket.
- Please ensure to contact our call center for any repair or service required for the products.

WARNING!

It is **STRONGLY RECOMMENDED** that you **ANCHOR** this product.

Toppling furniture and TV's can cause serious injury or death.

TO HELP AVOID ANY SERIOUS OR FATAL INJURY, WE STRONGLY RECOMMEND THAT THIS PRODUCT BE PERMANENTLY FIXED TO THE WALL OR OTHER SUITABLE SURFACE. FIXING DEVICES ARE NOT INCLUDED SINCE DIFFERENT SURFACE MATERIALS REQUIRE DIFFERENT ATTACHMENTS. PLEASE SEEK PROFESSIONAL ADVICE IF YOU ARE IN DOUBT WHAT FIXING DEVICE TO USE.

If a television is not positioned in a sufficiently stable location, it can be potentially hazardous due to falling. Many injuries, particularly to children, can be avoided by taking simple precautions such as:

- Using cabinets or stands recommended by the manufacturer of the television.
- Only using furniture that can safely support the television.
- Ensuring the television is not overhanging the edge of the supporting furniture.
- Not placing the television on tall furniture (for example, cupboards or bookcases) without anchoring both the furniture and the television to a suitable support.
- Not standing the television on cloth or other materials placed between the television and supporting furniture.
- Educating children about the dangers of climbing on furniture to reach the television or its controls.

Please make sure upon positioning this product, the place is:

- Not wet or damp and Well ventilated
- Away from direct sunlight or heaters.
- Away from splashes or food.
- Protected from excessive dust or grease.
- Do not install this equipment in a confined space such as a bookcase or similar unit.
- Do not install the TV set near heat sources such as radiators, stoves or other audio visual equipment that produce heat.
- Do not place containers with liquids, if liquid falls inside the products it may result in short-circuit, fire or electric shock.
- Do not place small metallic objects on top of the unit. Metal object falls inside the product it may result in short-circuit, fire or electric shock.
- Do not use or store flammable or combustible materials near the unit. Doing so may result in fire or explosion. Do not place any naked flame sources, such as lit candles, cigarettes or incense sticks on top of the TV set.
- The antenna must be installed away from high-voltage power line,
- Please contact an antenna professional installer to install the antenna to avoid incorrect installation which could result in fire, electric shock or serious injury.
- Install the unit at a reasonable distance from the wall to ensure sufficient ventilation.
- If mains plug or an appliance coupler is used as the disconnect device, the disconnect device shall remain readily operable.



This equipment is a Class II or double insulated electrical appliance. It has been designed in such a way that it does not require a safety connection to electrical earth.

The availability of and access to Contents and Services in TV Device are subject to change at any time, without prior notice. Some apps that appear on the packaging may not be preinstalled; internet connection is required for download. Content partners may vary depending on country.

Netflix streaming membership required. 4K Ultra HD availability subject to your Netflix subscription plan, Internet service, device capabilities, and content availability. www.netflix.com/TermsOfUse.

Amazon, Prime Video, and all related logos are trademarks of Amazon.com, Inc. or its affiliates. Amazon Prime membership and/or Prime Video fees apply. See primevideo.com/terms for details.

INSTALLATION

Attaching the stand

Step 1

Place a soft cushioned material on top of a flat surface to prevent damaging the screen panel. Then place the TV screen flat on top, with the screen side facing down, as illustrated on the right.

Step 2

Align the stand leg to the installation point, as illustrated on the right.

Step 3

Tighten the screws (supplied) with a screwdriver to affix the stand to the panel, as illustrated on the right.

CAUTION!

Do not apply excessive force as this may damage the screw holes.

California Prop 65 Warning

⚠️ WARNING:

This product contains Ethylene Oxide which is known to the state of California to cause cancer birth defects and other reproductive harm. Do not ingest.

For more info go to: www.P65warnings.ca.gov

BACK OF TV

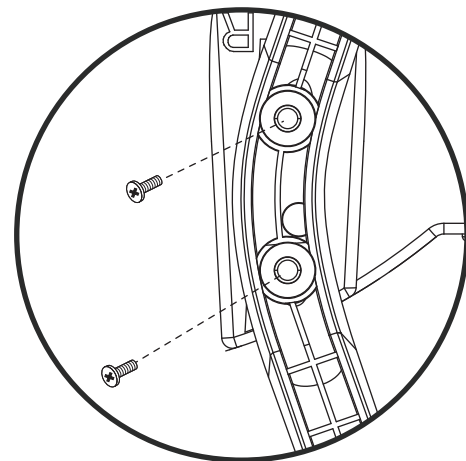
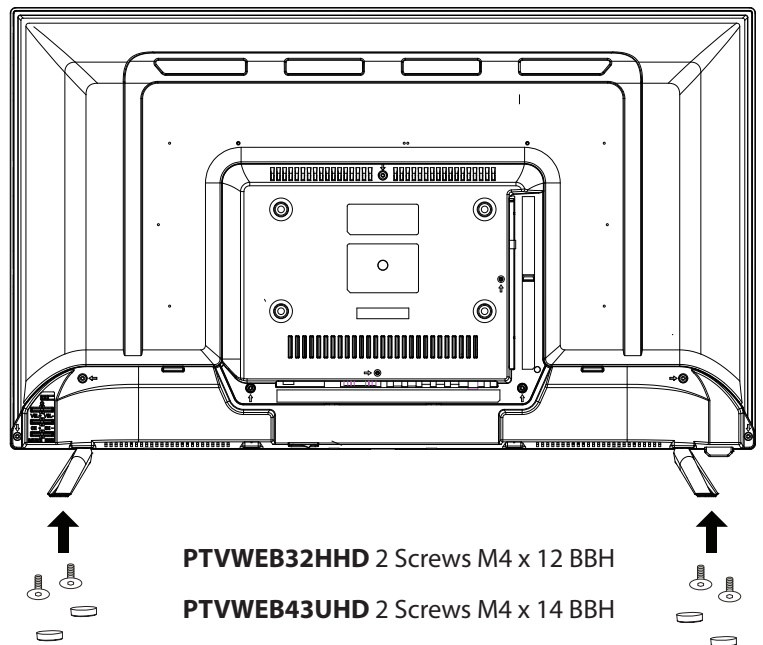

4 Screws M4
(Provided with TV unit)

CONTROLS AND CONNECTIONS

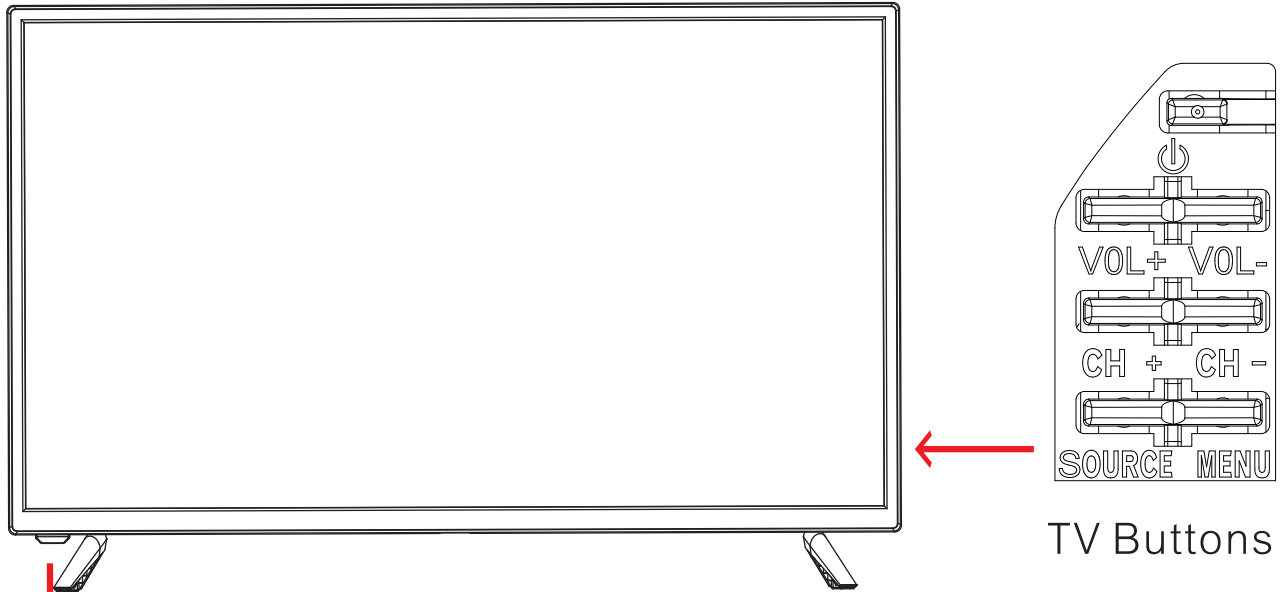

IR Sensor
Power Indicator

TV Buttons

Button	Description
VOL+, VOL-	Press to adjust the volume level, or press to select or adjust a menu item.
CH+, CH-	Press to select desired channels, or press to select or adjust a menu item.
MENU	Press to display the setup menu on the TV screen.
SOURCE	Press to select TV or all video input modes.
POWER	Press to turn TV on or turn to standby mode.

CONTROLS AND CONNECTIONS

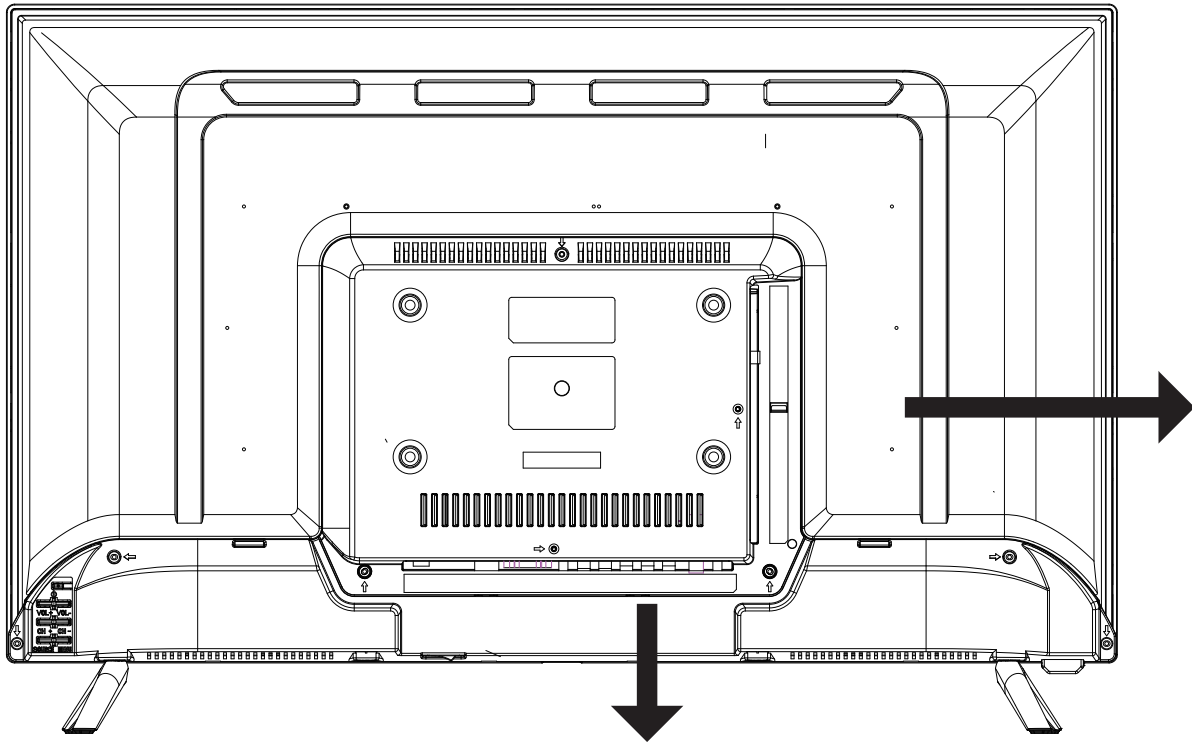







PTVWEB32UHD



PTVWEB43UHD



Connector	Function	Description
	USB	Insert USB.
	RJ45	Connect to the Ethernet.
	AV IN	Video and Audio(L/R) input Terminal, Audio(L/R) can be used as YPbPr Audio input.
	EARPHONE	Connects audio amplifier or other device with that audio input.
	HDMI	Connect to equipment with HDMI output.
	RF	Antenna Input terminal Connect to equipment with antenna output or wall antenna socket.
	OPTICAL	Connection for Digital Coaxial input for Audio Amplifier.

REMOTE CONTROL



POWER: ON/OFF.

TV : Switch to TV.

Q : Search.

SUBTITLE: Enable/disable subtitles.

⚙️ : Enter the Quick Settings menu.

📺 : Select an input source.

0-9: Number selection key.

LIST: Checking the saved programs.

⋮ : It displays the additional buttons on the remote control.

QUICK ACCESS: Brief : Number Key / Hold : Quick Access

VOL+/- : It adjusts the volume level.

CH+/- : You can change the program.

FAV: Press to display the favourites list.

GUIDE: You can check the program.

🔇 : Mutes the sound.

▶ : Play.

🏠 : Displays the Home menu.

⏸ : Pause.

BACK: Move to the previous step.

EXIT: Closes the menu.

⊙/OK: Select current option that's highlighted.

⬆️⬇️⬅️➡️⬆️ : UP/DOWN/LEFT/RIGHT buttons to navigate the on-screen menus.

TEXT: Open the TEXT.

INFO: Show info of current program.

SAP: Press this button to display and select different TV audio language.

MOVIES: Search Movies.

REC: Launch Record.

📺 : Launch Live Playback.

NETFLIX: go to Netflix.

Prime Video: go to Prime Video.

🔴 🟢 🟡 🔵 : Corresponds to various colour functions in the menu or teletext.

MENUS

GETTING STARTED WITH WEBOS TV

Live TV Preparation

Watching Broadcast TV

1. Connect the broadcast antenna to the TV.

You can also connect a piece of equipment that can receive broadcasting such as a set-top box instead of the antenna.

Launch ⚙️ → ⓘ → connection → device connection settings → universal control settings.

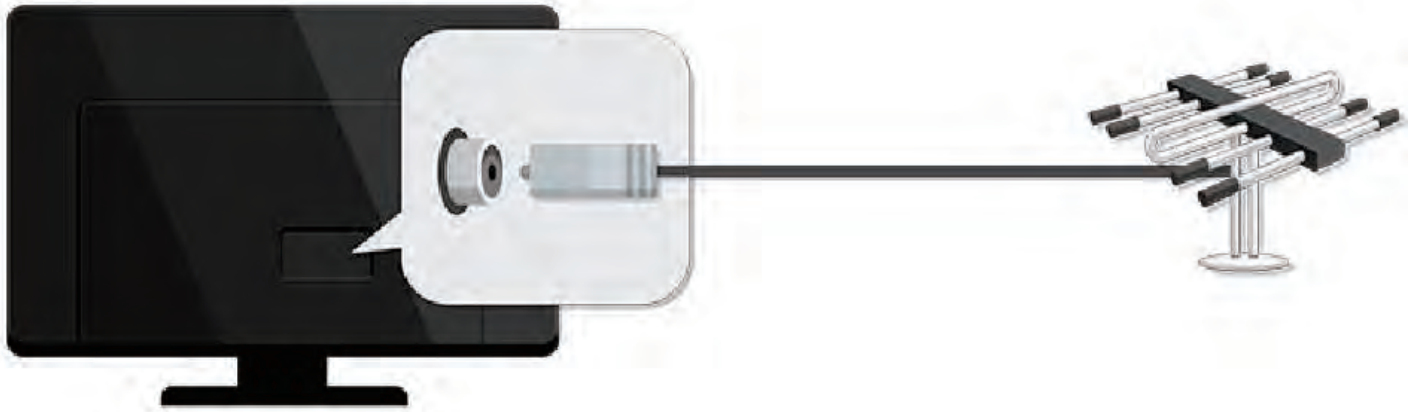

2. Start the ⚙️ → ⓘ → programs → program tuning (program tuning & settings) → auto tuning.

Finds and adds only programs being broadcast.

- To solve a problem related to this function, refer to the troubleshooting section of user guide.

Connecting to the Network

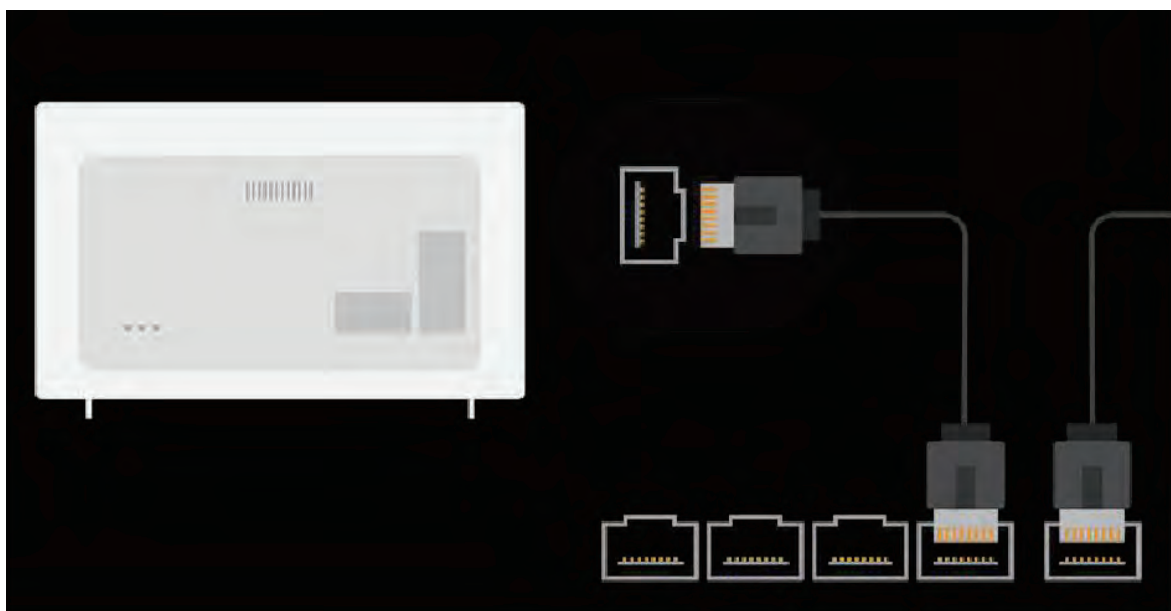

If you configure settings for the network, you can use various services such as online contents and applications.

SETTING A WIRED NETWORK



1. Connect the Lan port (RJ45) of the tv and the router using a an cable. The router should be connected to the Internet beforehand.
 - If the router supports DHCP, the tv is automatically connected to the network when you connect the tv to the network with a Lan cable.



If the network is not automatically connected

2. Press the  button on the remote control.
3. Selected connection  → network connection settings → wired connection (Ethernet).

To see the details, click the settings → connection → network → connection settings in user guide.

WIRELESS NETWORK SETTING



1. Turn ON the power of the router connected to the internet.
 2. Press the  button on the remote control.
 3. Select  → connection → network connection settings → wi-fi connection.
 4. When the network search is complete, the list of networks available for connection is shown.
 5. Select a network to connect.
 6. If your wireless Lan router is password protected, enter the password configured for the router.
- To see the details, click the settings → connection → network connection settings in user guide.

NETWORK SETTING WARNINGS

- Use standard Lan cable (connect to cat7 or higher with RJ45 connector, 10 base-T, or 100 base Tx Lan port)
- Resetting the modem may fix some network connection problems. Turn the power OFF, disconnect and reconnect it, and then turn the power on to solve the problem.
- The manufacturer is not responsible for any network connection problems or any faults, malfunctions, or errors caused by network connection.
- The network connection may not work properly because of network settings or the Internet Service Provider.
- DSL service must use a DSL modem; and cable service must use a cable modem. Since only a limited number of network connections may be available, TV network setting may not be used depending on the contract with Internet Service Provider. (If the contract does not allow more than one device per line, only the already-connected PC may be used.)

- A wireless network can experience interference from other devices that use the 2.4 GHz frequency (wireless phone, BT device, or microwave oven). Although interference can also happen when using the 5 GHz frequency, it is less likely to occur.
- The wireless environment can make wireless network service run slowly.
- Failure to turn off all local home networks may cause excessive traffic on some devices.
- The access point device must support wireless connections and wireless connection feature must be enabled on the device to have AP (access point) connection. Contact the service provider for availability of wireless connections on the access point.
- Check SSID and security settings of the AP. Refer to the appropriate documentation for SSID and security settings of the AP.
- Invalid settings of network devices (wired/wireless line sharer, hub) can cause the TV to operate slowly or not operate properly. Install the devices correctly according to the appropriate manual and network.
- The connection method may differ depending on the AP manufacturer.
- To solve a problem related to this function, refer to the Troubleshooting section of User Guide.

HOW TO OPERATE TV

Pairing the Magic Remote

LEARN MORE ABOUT MAGIC REMOTE

You can select the functions you want easily and conveniently by moving and clicking the cursor on the TV screen, just as you would use a mouse on a computer screen.

- You can purchase the Magic Remote separately if it is not provided.

PAIRING THE MAGIC REMOTE

You must pair the Magic Remote with the webOS TV to use it. Pair the Magic Remote prior to use as follows:

1. Turn on the TV. After about 20 seconds, point the remote towards the TV and then press the Wheel (OK).
2. The remote control will automatically be registered, and the pairing completion message is displayed on the TV screen.
 - If the Magic Remote failed to register, turn the TV off and then on again, and then try to register again.

RE-REGISTERING THE MAGIC REMOTE

If the Magic Remote's pointer does not appear on the TV, you must re-register it.

1. Hold the remote control towards the TV and press and hold GUIDE button until the instruction appears.
2. The previously registered remote control is deregistered and then registered again.

USING THE MAGIC REMOTE

1. If you shake the Magic Remote left and right or turn its wheel while pointing it at the TV, a pointer will appear on the TV screen.



If you move the remote control to the direction you want, the pointer follows the movement.

2. Move the pointer to the location you want and press the Wheel (OK) button to execute the function.



3. If the pointer has not been used for a certain period of time, it will disappear. When the pointer disappears from the screen, shake the Magic Remote right and left. It will then re-appear. The pointer will disappear if you press the up, down, left or right buttons, and the remote will work as a conventional remote.
- If the pointer is not responding smoothly, you can reset the pointer by moving it to the edge of the screen.
 - Use the remote control within the specified range (within 10 metres). The device may not function properly when outside the working distance or when an obstacle blocks the line of sight.
 - Depending on the peripherals (wireless router, microwave oven, etc.), communication failures may occur.
 - Impacts can cause the Magic Remote to malfunction.
 - Beware of hitting the furniture, electronic equipment or other people nearby when using the Magic Remote.

Using TV Functions through Speech



You can access various functions of the tv easily and quickly through speech recognition.

1. Press and hold the  button on the remote control and speak out the function you want to launch or the keyword you want to use for your search.
2. Once you release the  button after your speech input, the corresponding function is launched.



- Some models may not be supported.
 - Your Location must correspond to the language for exact search results. Some functions may not be available if your location settings and language settings are different.
- You can change the language in  →  → General → Language → Menu Language.

CAUTIONS FOR SPEECH RECOGNITION

- Voice recognition requires a Magic Remote, which may not be supported by certain models.
- To use all speech recognition features, you need to set your programmes, region, etc. Otherwise, you cannot use some features.
- You must have a network connection to use the speech recognition feature.
- If you have a network connection, you need to accept the terms and conditions to use speech recognition.
- To control the set top box connected to the TV with the voice recognition feature, go to  →  → Connection → Device Connection Settings → Universal Control Settings to set up a universal remote control.
- It is recommended to point Magic Remote toward the set top box after the voice input.
- The rate of speech recognition may vary depending on the characteristics of the user (voice volume, pronunciation, accent, and talking speed) and the surroundings (noise and TV volume).
- To achieve accurate recognition of your speech, you must pronounce words in a slow and accurate manner at an appropriate voice volume at a distance of about 10 cm away from the Magic Remote's microphone.
- If your speech is not recognised properly, speech recognition may operate differently than you originally intended.

Speech To Text

USING SPEECH TO TEXT

You can enter text in text fields using the speech recognition function.

Select the  button on the keyboard screen to switch to speech input mode. Some models may not be supported.

1. Move the Magic Remote pointer in the text box to open the virtual keyboard.



2. Press the  button on the virtual keyboard.
3. After the voice recognition information window opens as shown below, speak into the microphone on the remote control slowly and clearly.

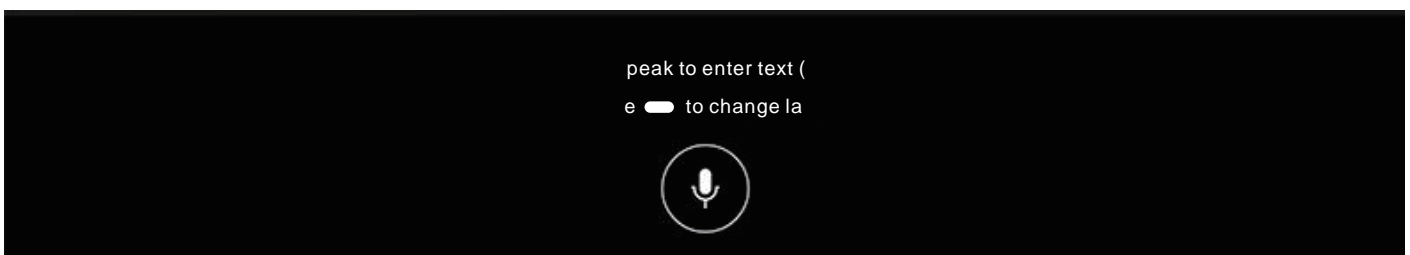

4. If there are words similar to that which you spoke out loud, you may see a list of multiple results as shown below. If you do not get the results you want, press RETRY to try again. Select a result and it will be displayed on the text box.

Finite Challenge

Infinite Challenge

Entrapment Challenge

Cautions When Using Speech to Text

- Check the network connection before using the Speech to Text function.
- You can change the language in ⚙️ → ⓘ → General → Language → Menu Language.
To switch to another speech recognition language temporarily, press the 🔴 (RED) button in the voice recognition information display window.
- You can only use this function to agree to voice recognition terms.
- The Speech to Text rate may vary depending on the user's characteristics (voice, pronunciation, intonation and speed) and the environment (noise and TV volume).
- To improve the accuracy of Speech to Text, you must speak clearly and loudly about 10cm from the Magic Remote microphone.
- Voice recognition is unavailable in any password input field and the address bar of your Web Browser (excludes general search).

Launching Apps through QUICK ACCESS

Using Apps quickly and easily with QUICK ACCESS

Press and hold a number button on the remote control to open an app or to activate an external input registered to the button.

Setting QUICK ACCESS

1. Launch the app or select the program or input you wish to assign.
2. Press and hold the number button (1-9) you want to register.
3. When the registration pop-up window appears, select **Yes**.
 - If you press and hold a number button that has already been registered, the registered function will be performed.
 - To see the items that can be registered, select a number that has not been registered in the QUICK ACCESS edit mode.
 - If you are in a mode where QUICK ACCESS cannot run, no action will be performed.
 - If you delete a registered app, QUICK ACCESS will be deregistered as well.

Checking and Editing QUICK ACCESS

Press and hold the 0 button on the remote control.

The QUICK ACCESS edit screen appears.

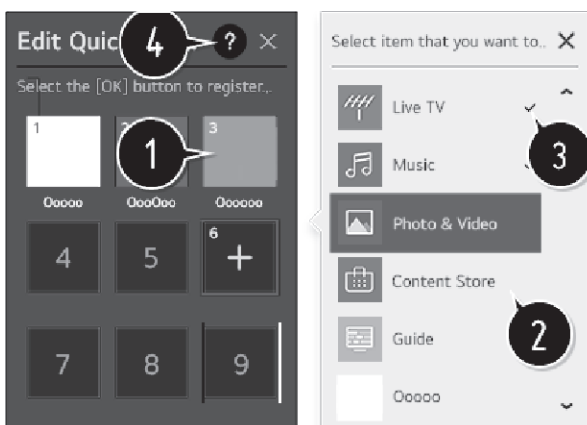



1. Selecting a number that has already been registered allows deregistering it.
2. When you select a number that has not been registered, items that can be registered will be shown.
3. An item that has been registered to a different number is indicated with a check mark.
4. You can view a brief instruction for this function.

ENJOY LIVE TV

Recording

Using the Recording Functions

1. Connect a USB HDD or USB stick to a USB port. It is recommended that you record to a USB HDD.
2. During watch the Live broadcast, press the Wheel (OK/⊙) button.
3. Press the  button at the bottom of the screen.
4. If you want stop the recording, press the  button.



Attention of Recording

- While recording, press the Wheel (OK/⊙) button to display information about the recording.
- The duration of the recording can be set before the recording starts.
- If multiple USB storage devices are connected, the last recorded storage device is selected automatically.
- The available capacity of the USB HDD partition must be at least 1 GB.
- There must be at least 4 GB of partition size on USB stick.
- The recordable time may vary depending on the capacity of your USB storage device.
- Upon the initial attempt to record to the USB memory, the TV will perform a performance test. Start recording after the test has been completed.
- Because of the content protection technology used, the recorded video cannot be played on PCs or other TV models. Also, the video cannot be played if the TV's video circuit is replaced.
- Do not remove the USB cable while recording.
- If you force your TV to power off while recording, the recorded content may not be saved.
- You should stop the recording and check that the program has been recorded before turning the TV off.
- Recording quality depends on the performance of the USB storage device.
- If a USB storage device is faulty, recording may not be completed properly.
- The USB storage device may not work or function properly when a USB hub or extension cable is used.
- Recording may be interrupted if the remaining storage capacity is insufficient. Use of a storage device with sufficient space for recording is recommended.
- The configurable items differ depending on model.
- Some functions may not be available while recording is in progress.
- Only broadcast programmes you view through the antenna input terminal can be recorded.
- BT and the USB port may not work properly when recording with a USB storage device.
- Recordings that are less than 10 seconds long will not be saved.
- You can save up to 600 pieces of content on a single partition.

Playing Recorded TV Programs

Managing Recordings

You can view and play recordings stored on storage devices by using the Recordings app.

A. Press the remote control's LIST button, and select the Recordings tab on the left side of the screen.

B. Select the  at the top right.

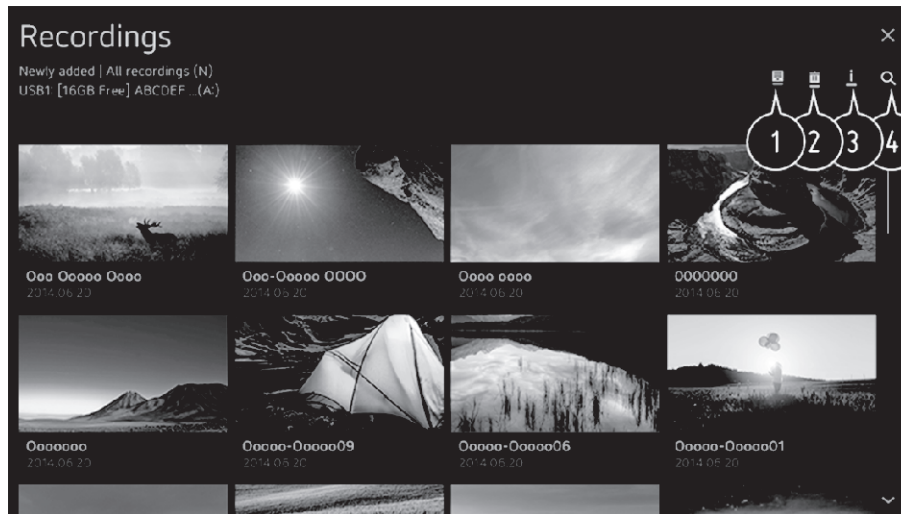

1. Select the storage device to play, the type of recording, the sorting method, and the view type.
2. Select and delete the desired content.
3. Display detailed information about the content. You can change the title of the content in the detailed information pop-up.
4. **Launch Search:** You can only play recordings made on this TV.

Playing Recordings

You can access and operate basic features such as playback and pause on the playback screen.

A. Select your desired recording from the Recordings app.

B. You can control the playback of your desired recording by pressing the Wheel (OK/⊙) button during playback.



1. You can operate basic playback-related features.
2. You can do the settings related to play on repeat of the video.
3. This switches you to a screen where you can set up additional features.

Setting up Additional Features

- A. Press the Wheel (OK/⊙) button during the playback of the desired recording.
- B. Select  on the screen.



1. Return to Recordings.
2. Display recordings list below thumbnail image while recordings playback.
3. Turn subtitles on or off.
4. Select audio language that can be outputted.
5. You can set continue watching to resume playing from the last viewed scene.
6. Returns to the basic operation screen.

The configurable items differ depending on model.

CONNECTING EXTERNAL DEVICES

Using Home Dashboard

You can select or control a device (mobile, external device, Home IoT Devices, etc.) connected to the TV.

Press the  button on the remote control and select Home Dashboard.

You can also press and hold the  button on the remote control.





1. You can check and select the smart device connected with the **ThinQ** app. Refer to Connecting External Devices Connecting Smart Devices in User Guide for more information on the action.
2. You can play sound from a smart device connected via BT. Please refer to Connecting External Devices Playing Sound from a Smart Device through the TV's Speakers in User Guide for more information on the action.

3. You can check and select the external device connected through the external input port or network.
4. The currently selected output speaker is displayed, and you can navigate to the output speaker settings screen.
5. You can view and select the connected storage device.
6. You can check and control the device connected via the Home IoT. Please refer to Connecting External Devices Connecting Home IoT Devices in User Guide for more information on the action.
7. You can easily control your device by presetting the desired operations.
8. **Sign In:** You can log in/out to and from the ThinQ account you created on mobile.
Edit: You can edit the name of the device connected to Inputs or Home IoT Devices or configure the related settings.
9. It refreshes the device list.
10. Exit the Home Dashboard. Available settings vary depending on the model or region.

Connecting Home IoT Devices

You can check and control the status of the connected Home IoT Devices.

1. Install **ThinQ** app on your smartphone.
2. Log in to your ThinQ account, and register your own ThinQ device.
3. Press the  button on the remote control and select Home Dashboard.
4. Press the  at the top right to select the Sign In.
 - If you are in an area where the ThinQ app is not in service, ThinQ device connection will not be supported.
 - If you are controlling the external device from your mobile app, you might not be able to control the device from your TV. Quit the mobile app to control it from your TV.



1. You can easily control your device by presetting the desired operations.
2. You can log in/out to and from the ThinQ account you created on mobile.
3. **Edit List:** You can rename, Show/Hide or change the order of the devices connected to Home IoT Devices.
Notification: If you turn it On, you can receive notifications about the status of the Home IoT Devices.
Delete: You can delete the connected device. You can only delete certain devices from the TV.
4. You can check the connection guide for Home IoT Devices. Connect and display the devices registered to your ThinQ account. Once the device is connected, the card will be changed to a smaller size and appear at the bottom of the device connection list.

- Available settings vary depending on the model or region.
- IoT devices that can be connected to a TV are subject to change without notice.
- Connectable ThinQ devices and available functions may differ between mobile and TV.

Connecting Smart Devices

You can use a variety of features by connecting the TV to a smart device.

Connecting Your Smart Device to a TV Using the ThinQ App



1. Download the ThinQ app from the app store of your smart device. You can download the app easily by scanning the QR code.

Android



IOS



2. Connect your TV and smart device to the same Wi-Fi network. You can check the Wi-Fi network of TV at  →  → Connection → Network Connection Settings → Wi-Fi Connection.
3. Run the ThinQ app installed on your smart device.
4. Follow the instructions from ThinQ app to connect your smart device to the TV. When your account information of ThinQ is linked to the TV, you can manage the IoT devices linked to your account using Home Dashboard of the TV.

Controlling Your TV with the ThinQ App

You can tap the buttons on your smart device's screen to control the TV.









1. When watching a broadcast, you can control the programme, volume, etc. or select the external input with voice commands instead of using the remote control.
2. You can use the same functions as the Magic Remote's pointer and arrow keys.
Some controls may be limited in external input mode.
 - The app's screen and functionality are subject to change without prior notice.
 - Available features may differ depending on your country and OS.

NOTE:

TV Rating Locks/Enabling Programme Locks/Application Locks/Input Locks-----The initial password is set as "0000". When France or Norway is selected for Country, the password is not "0000" but "1234".

Resetting a Lost Password

If you lose the password you set, you can reset it as follows:

1. Press the  button on the remote control.
2. Select  → General → Safety.
3. Press  (Programs) ^ →  (Programs) ^ →  (Programs) v →  (Programs) ^ on the remote control.
The master password input window will appear. Enter the numbers "0313" in the master password input window, then press Enter. The password will be reset.

FAQS

GENERAL PROBLEMS WITH TV SET

PROBLEM	SOLUTION
No Power	Make sure power plug is inserted correctly into power outlet.
No Picture	Make sure the following is connected correctly <ul style="list-style-type: none"> • Adjust the antenna • Move TV away from any products that may cause interference. • Auto tune the unit again • Go to another channel
No sound or distorted sound	<ul style="list-style-type: none"> • Take sure everything is connected correctly • Check if input settings for TV is correct • Audio settings are properly set • Make sure volume is not muted. • If earphones are connected, unplug them. • Adjust the volume
No operation can be performed with the remote control	<ul style="list-style-type: none"> • Check the batteries are inserted correctly • Replace batteries if they have been used for awhile • Make sure to point remote control at the TV sensor and try again • Make sure you are not further then 6m away from TV. • Remote any obstacles that may be in the way of direct line of sight from remote control to the TV sensor.

PTVWEB32HHD SPECIFICATION

Operating System	Powered by webOS
Display Device	32"
Resolution	1366x768
Display Colours	16.7M
Contrast ratio:	3000:1
Aspect Ratio	16:9
Multimedia Playback Format under USB Mode	Movie: .asf/ .avi/ .Mp4/ .MOV/ .3gp/ .mkv/ .ts/ .trp/ .tp/ .mpg/ .mpeg/ .vob
	Music: .Mp3/ .WAV/ .ogg/ .flac
	Photo: .JPEG/ .JPG/ .JPE/ .PNG/ .BMP
Power Source	100-240V~ 50-60Hz
Power Consumption	55W

PTVWEB43UHD SPECIFICATION

Operating System	Powered by webOS
Display Device	43"
Resolution	3840x2160
Display Colours	16.7M
Contrast ratio:	4000:1
Aspect Ratio	16:9
Multimedia Playback Format under USB Mode	Movie: .asf/ .avi/ .Mp4/ .MOV/ .3gp/ .mkv/ .ts/ .trp/ .tp/ .mpg/ .mpeg/ .vob
	Music: .Mp3/ .WAV/ .ogg/ .flac
	Photo: .JPEG/ .JPG/ .JPE/ .PNG/ .BMP
Power Source	100-240V~ 50-60Hz
Power Consumption	85W

The logo for Pyle, featuring the word "PYLE" in a bold, black, sans-serif font. The letter 'Y' is stylized with a curved bottom. The background of the entire page features abstract geometric shapes in shades of blue, dark blue, and grey, creating a modern, layered effect.

PyleUSA.com

Questions? Comments?

We are here to help!

Phone: (1) 718-535-1800

Email: support@pyleusa.com