

SereneLife



SLDP85

Professional Spinning Dancing Pole

Portable & Removable Stripper Fitness Pole,
Great For Training & Exercise
(Gold Surface)

User Manual

FINDING A SUITABLE EXERCISE AND DANCE AREA

Try to find a suitable area in the centre of your room, where you would like to install your pole. To use Dancing Pole properly you need to be able to rotate around the pole with your arms outstretched and NOT be able to hit or touch anything whilst rotating. Find the area by rotating around an imaginary pole with your arms outstretched, you can use a chair as an imaginary pole or, measure a circle with a diameter of approximately 3.0~3.5mtrs (10~11.5ft). This area will enable you to fully extend your arms.

Once you have located the correct sized clear area you can look for the ceiling joists above the area you have selected.

When you are installing, first measure the height of your ceiling to the ground in advance; then select the appropriate extension pole according to your needs. Do not tighten the poles at the beginning of installation. After all installations, adjust to the tightest.

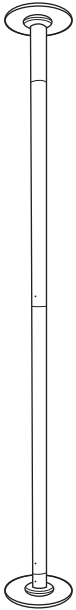

81.5 in to 88.6 in
6.7 ft to 7.3 ft

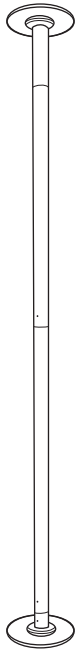

88.4 in to 95.5 in
7.3 ft to 7.9 ft

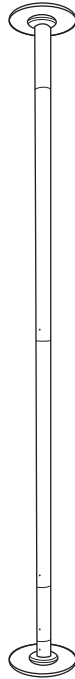

94.9 in to 101.9 in
7.9 ft to 8.4 ft

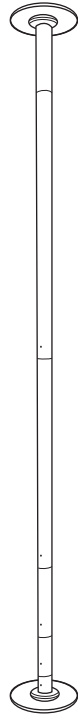

101.7 in to 108.2 in
8.4 ft to 9 ft

Make sure you measure properly the height of what will support your pole.

BEFORE USING YOUR POLE

Mis-using a pole can be dangerous, not only to the user but also to anyone close to the pole. The use of a dance pole is always at the user's discretion, and it is the user's responsibility to check the pole is installed correctly and safely before use.

Pole Exercise is extremely physical and uses muscles that you will not have used before and therefore if you are not warmed up; muscle damage, strains and injury can occur. Before using the Dance Pole, it is mandatory to warm up and, after use, cool down. It is highly recommended that before you use your Dance Pole you purchase a suitable DVD to learn the basic moves. Never try moves beyond your ability without an instructor. If at any time whilst using your pole you feel uncomfortable, your muscles hurt, or you are short of breath – take a break. Always rest between moves and exercise sensibly, if you experience any health issues, seek medical advice.

⚠ SAFETY INSTRUCTIONS

1. Never use oil and/or lotion on your hands or body before using the dance pole. The oil and/or lotion transferred onto the pole will make it slippery and hard to hold, which might cause serious bodily injury.
2. The dance pole should not be installed under false or suspended ceilings that are not sturdy enough.
3. Never place a carpet under the dance pole as it could affect the stability of the product.
4. Before the installation, all protecting film covering the parts must be removed.
5. The horizontal weight capacity of this product is 280 kg/617 lbs. The vertical weight capacity of this product is 500 kg/1102 lbs. Never apply any weight over the weight capacity on this dance pole.
6. Ensure that the 3.5 meter peripheral area of the dance pole is free of any objects.
7. We recommend the assembly of this product should be carried out by two people.

PACKAGE CONTENTS

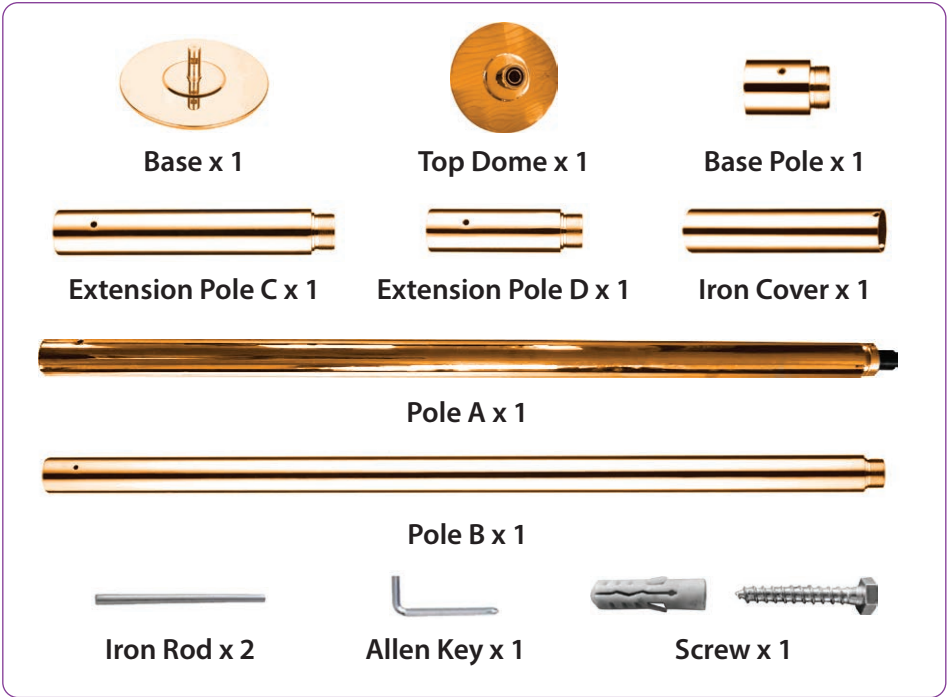

ASSEMBLY INSTRUCTIONS

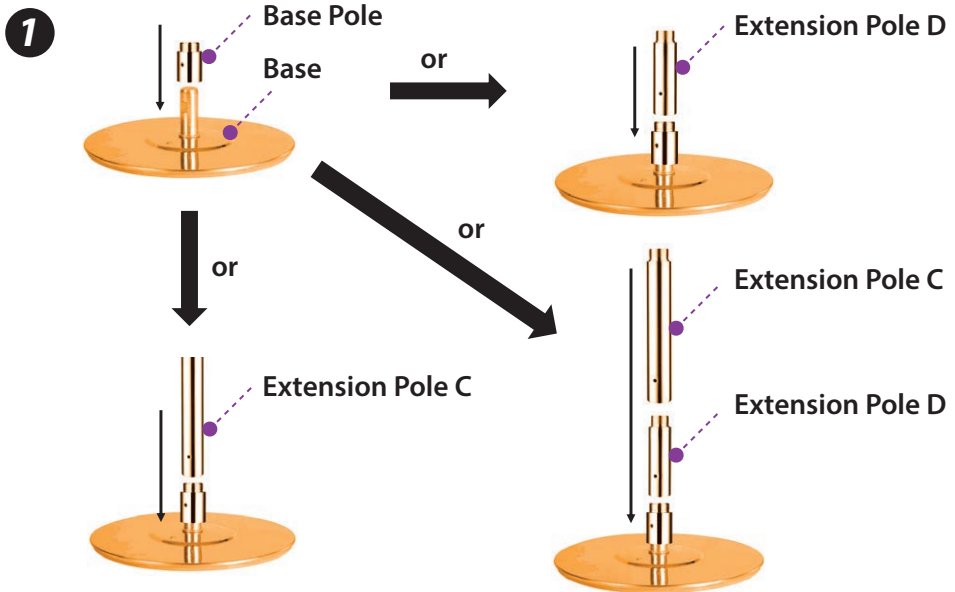

1. Use the allen key to loosen the screws on the base pole and install the base pole on the base. Ensure one of the screws on the base pole is aligned to the "Y" letter on the base (Fig 1). After that, retighten the screws.

2. Measure the distance between your ground and ceiling and refer to the diagram below to decide if you need to install either the extension pole D or extension pole C or both of them, or none of them on the base. In the following steps, we will take scenario of installing Extension Pole C only as an example.

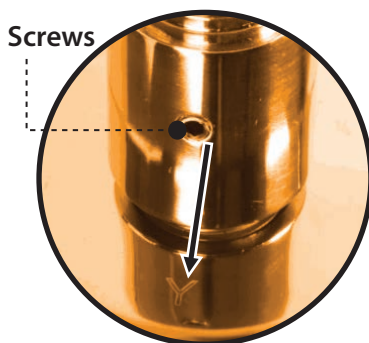
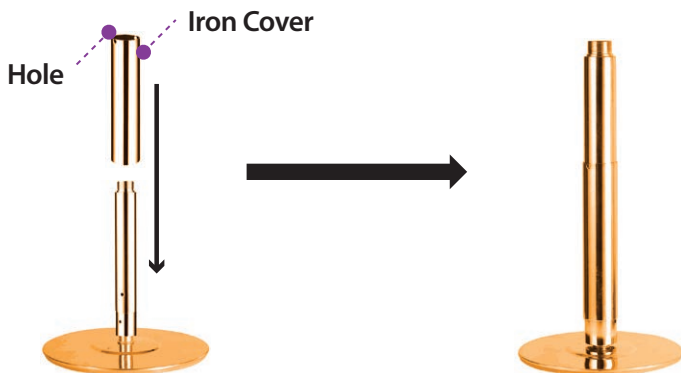

Fig 1

2



Slide down the iron cover through the pole and leave it on the base first. Ensure the end with two holes faces upward.

3

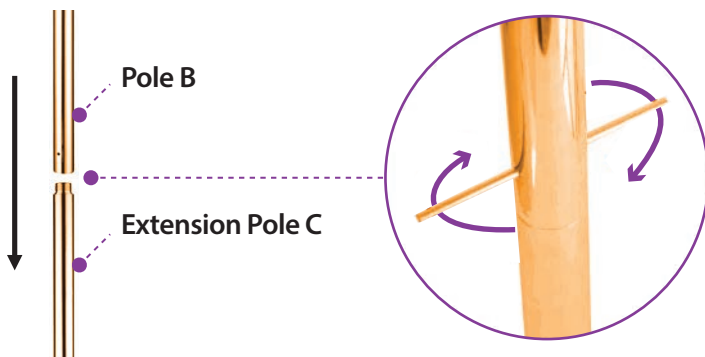

Install the pole B on the extension pole C as shown above. Fasten the connection with the iron rod.

4

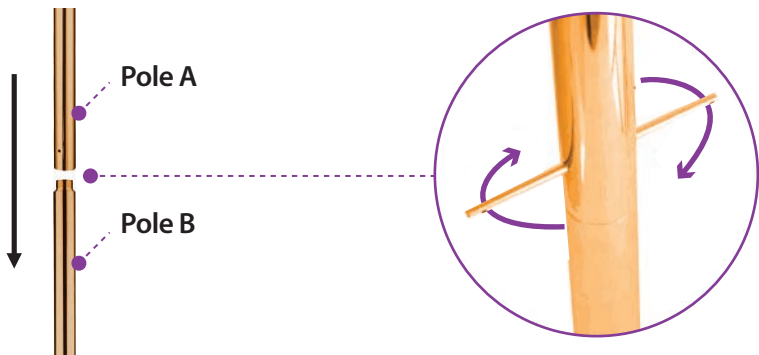

Install the pole A on the pole B as shown above. Fasten the connection with the iron rod

5

Install the top dome on the top of pole A as shown above. Rotate the top of pole A anticlockwise until the hole of the inner pole shows up.

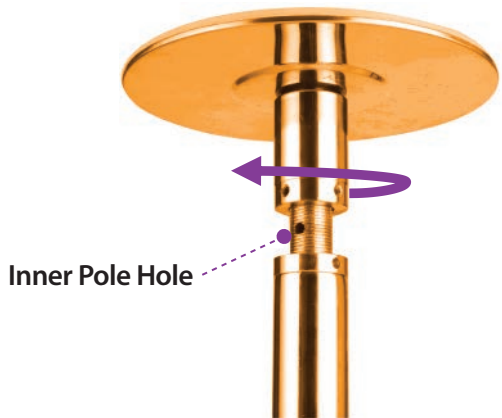

6

Use an iron rod to rotate the inner pole anti-clockwise until the upper base could not go up further against the ceiling. Please make sure that the pole is vertical between the ground and the ceiling and that the upper base is flat against the ceiling as shown in the pictures below.

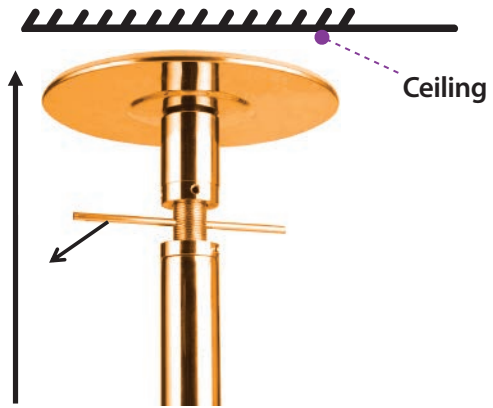

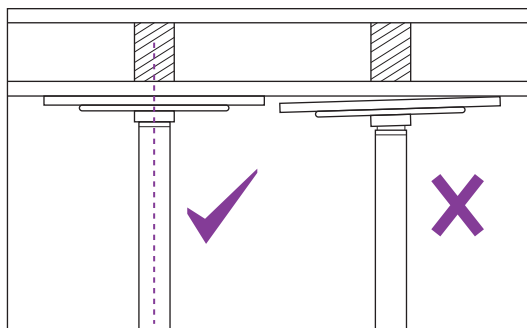
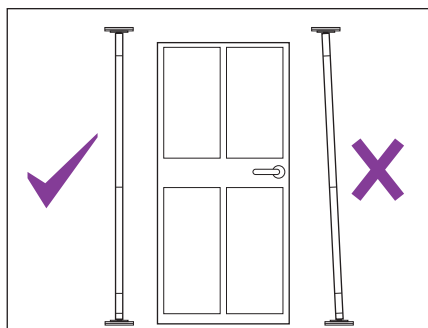

7

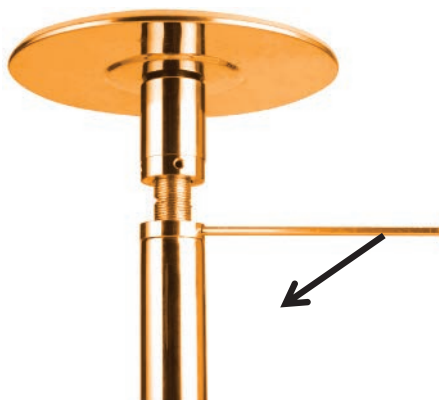

Use an iron rod to rotate the iron ring on the pole A clockwise to secure the dance pole.

8

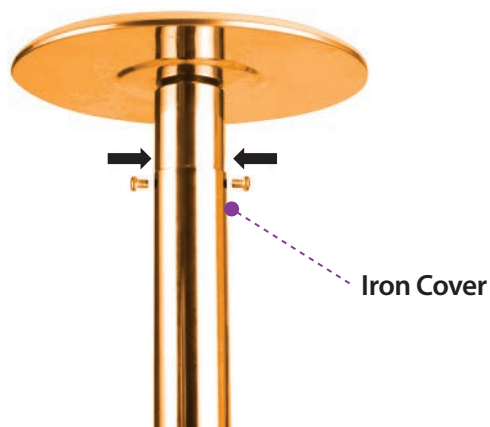

Ensure that the dance pole is set up firmly between your ceiling and ground. After that, slide the iron cover from the bottom base to the upper base. Fasten it with the two screws.

SWITCHING BETWEEN STATIC & SPINNING MODE

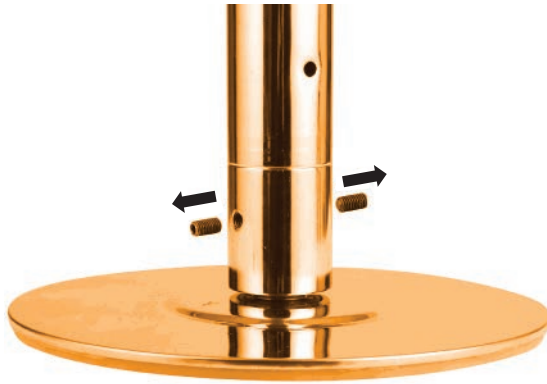

1. To set the dance pole into the spinning mode, loosen the two screws from the base pole.
2. To set it back to static mode, fasten the two screws back and ensure that one of them is aligned to the “Y” letter on the base.

WHAT TO WEAR

Clothing

When it comes to clothing - Less is Best! So try to keep your arms and legs uncovered. Pole work needs the friction created by skin contacted so T-shirt, crop top and shorts are best. However, you must feel comfortable so wear what you feel relaxed in (tracksuit bottoms etc.) even though this may mean you are unable to do some of the pole moves properly because of lack of grip.

Shoes

Again comfort is essential. Bare feet, dance shoes, or trainers are fine. Trainers have high friction so a trainer with a smooth as possible sole is recommended. Later boots and high heels are great for making you look and feel good.

Pole Dancing Gloves

Pole dancing gloves can protect your hands from blisters and burns. Most pole dancing gloves come in fingerless designs. This protects your palms when you are learning your moves. Since your fingers are free, you can feel the pole, but your hands will still be protected from injuries like blisters and friction burns.

Oils and Lotions

NEVER use oils or lotions on your hands or body prior to using your pole. This is very dangerous. The oil transfers to the pole making it slippery and impossible to hold and could cause you to have a serious accident.

NEVER USE OILS OR LOTIONS OF ANY TYPE PRIOR TO USING AN EXERCISE POLE.

POLE CLEANING

The pole will need regular cleaning as you use it. Clean your pole with baby wipes and then dry off with a tea cloth or towel. Keep two towels to hand one for the pole and one for you to wipe your hands and body with.

WARM UP AND COOL DOWN

It can not be stressed highly enough the need to warm up before exercise and then to cool down afterwards. Severe injury can be caused if you fail to warm up and in turn further damage can be caused if you do not cool down

TROUBLESHOOTING

If you follow the assembly instructions there should be no reason for you to have any problems with your Portable Dancing Pole. If you do have any problems please do not hesitate to contact our technical support line.

NEVER use your Portable Dancing Pole if you are in any doubt about its assembly, stability or how to use it.

Locked Tubes

Sometimes if the pole has been worked hard the main poles and/or extensions can tighten and become locked together. If tubes do become locked together use two release rods and twist both anti-clockwise.

If the tubes still will not release insert one of the release rods into the larger tube. Lay the tube on a hard surface and inserting the other release rod in the shorter tube give it a sharp tap with something solid, while holding the larger tube rigid. It does not require heavy force just the shock of the tap to release it.

Pole will not spin

This is normally due to the locking Hex screws not being unscrewed enough and flush with the outer surface of the pole. Check the screws.

The other reason could be that the pole is not assembled correctly (the cover flange is the wrong way round) or the pole is severely out of alignment. Go back to square one and reassemble your pole as per the instructions.

MAINTENANCE

Professional Spinning Dancing Pole should need very little maintenance.

Routine maintenance would be to check the pole joints are ok, check the bearings turn freely, check the base screws are tight and generally ensure your pole is exercise worthy. Should you have any concerns re your pole and it's suitability for use please call our technical support department.

⚠ CAUTION:

STORE YOUR PROFESSIONAL SPINNING DANCING POLE ONLY IN A WARM, DRY PLACE.



FEATURES:

- Practical Design for Building Muscles, Keeps Fit and Healthy
- Increasing Strength and Flexibility
- Easy to Use, to Install and to Store, Saves Space
- Height Adjustable and Smooth Connection
- High-Quality Steel Pipe Dancing Pole
- Strong and Durable Steel Structure
- Anti-Corrosion and Anti-Rust Surface
- Silicone Ring at the bottom of the Dome and Base Plate
- Suitable for Beginners, Professional Dancers, and Pole Fitness Lovers
- Uses for Physical Exercise at Home, Club, Bar, Gym or Prop for Photography

WHAT'S IN THE BOX:

- Base
- Top Dome
- Base Pole
- Extension Pole C 12.5" -inches
- Extension Pole D 7" –inches
- Iron Cover 7.5" -inches
- Pole A 38.6" –inches
- Pole B 38.6" –inches
- Allen Key
- Screw
- 1 Pair Black Gloves

TECHNICAL SPECS:

- Threaded Tube Size: 2.2mm
- Adjustable Height: 82" x 108" -inches
- Horizontal Weight Capacity: 617 lbs.
- Vertical Weight Capacity: 1,102 lbs.
- Construction Material: Steel Tube
- Steel Tube Diameter: 1.77" –inch
- Plate diameter: 9" -inches
- Overall Product Dimension (L x W x H): 9" x 9" x 108" –inches



SereneLife

Questions? Issues?

We are here to help!

Phone: (1) 718-535-1800

Email: jb@pyleusa.com