

3-Drawer Rolling File Cabinet

with Lock Combination, 360° Swivel Casters for Easy Mobility

serenelife™

USER GUIDE

Installation Instructions

Please read the instructions carefully before assembly and use. Clear the space for assembly and lay out all parts based on the Parts List. Ensure that all pieces are present.

1. Install upper and lower drawer cover and reinforce the screw.
2. Insert 2 universal wheel with lock into corresponding hole of the bottom plate at FRONT side.
3. Insert 2 universal wheel into corresponding hole of the bottom plate at BACK side.

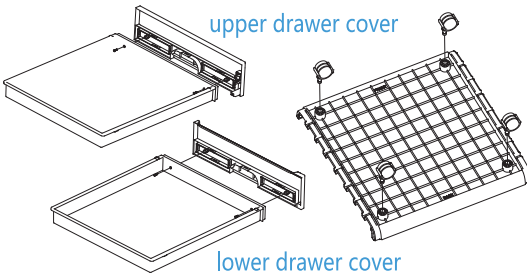

- 2 Insert Back side panel (A side) into left plate (A side), related buckle assemble in place.

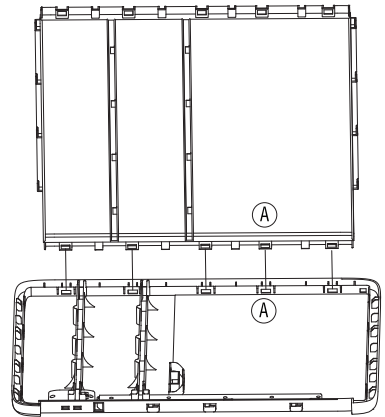

- 3 Insert the top and bottom panel into back panel. Install the left plate downward, top panel (B side) corresponds to left panel (B side), top panel (C side) to left panel (C side). Then install the middle rod terminal on the corresponding site of left panel.

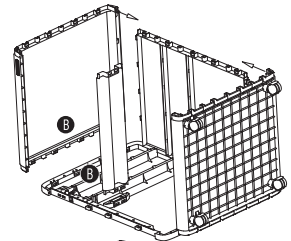

- 4 Install right plate downward, related buckle assemble in place.

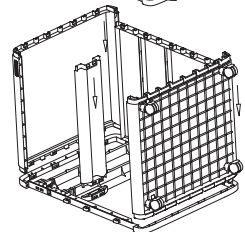
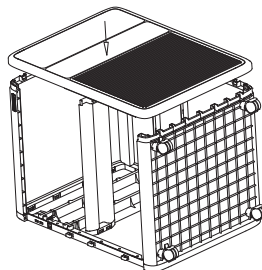

- Let the door and main body in 90 degrees, install the shaft hole corresponds to the door axis from top to bottom.
- Install the upper and lower drawer on the related track.

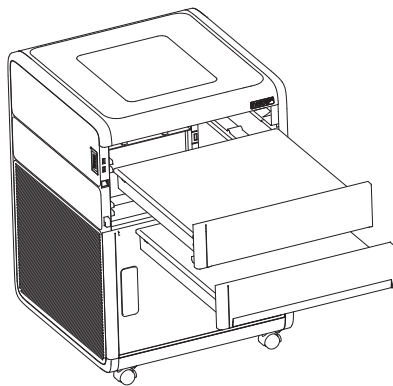
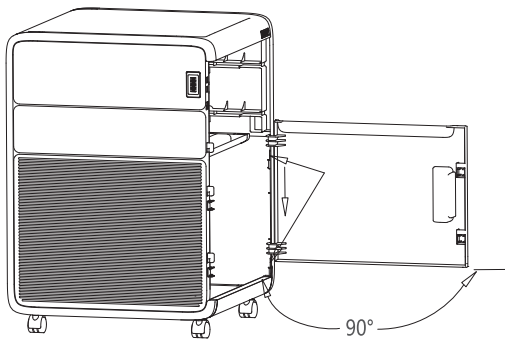

Steps to set the code of the cipher lock

- The initial code is **0000**.



- Switch the lever from Point B to Point A, after confirm about the initial code.

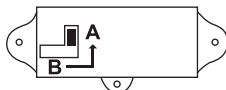

- Set your own code

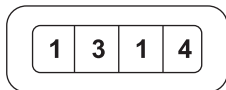

- Switch the lever from Point A to Point B, after the code is set.

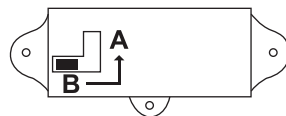

- Please memorize the code that you set and follow step 2, step 3 and step 4 to set a new code.

Note: For safety purpose, this box does not reserve any position for outer unlock device in its structural design and is not easy to dismantle after assembly. Please pay full attention to each steps of code setting, make sure the 4 digits lock codes set is exactly in parallel line, then put the code set lever back to "B" position, do not forget your set codes to avoid any inconvenience.

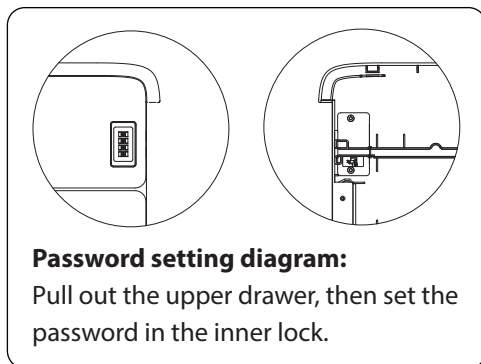

Questions? Issues?
We are here to help!
Phone: (1) 718-535-1800
Email: support@pyleusa.com