

SLSBKN850GY - SLSBKN850LB - SLSBKN850BL

Heavy-Duty Storage Bin

with Combination Lock

serenelife™

USER GUIDE

ASSEMBLY INSTRUCTIONS & LAYOUT

Please Note:

- Be sure to check the letters marked on the sides of the bin and align as shown in the images for proper orientation.
- Reference the images on the corresponding page.

1. Lay the rear panel down and start by adding in the side plates.

- First insert the left panel (B) into the rear panel (F), press the rear panel (F) down to secure the left panel (B)
- Then insert the right panel (C) into the rear panel (F), press the rear panel (F) down to secure the right panel (C)

2. Now add the base plate (D)

- First place the base plate (D) on the cushion to avoid scratches, then insert the 4 base pads (L) into the base plate (D).
- Then insert the assembled cabinet down into the slot corresponding to the base panel (D).

3. Finally we add the screws (H)

- First add screws to secure the side panel (B, C, E, F) to the base plate (D), then add screws in the corners to secure the side panels (B, C, E, F).
- Then align the hinge of the lid and attach with 2 screws on each side.

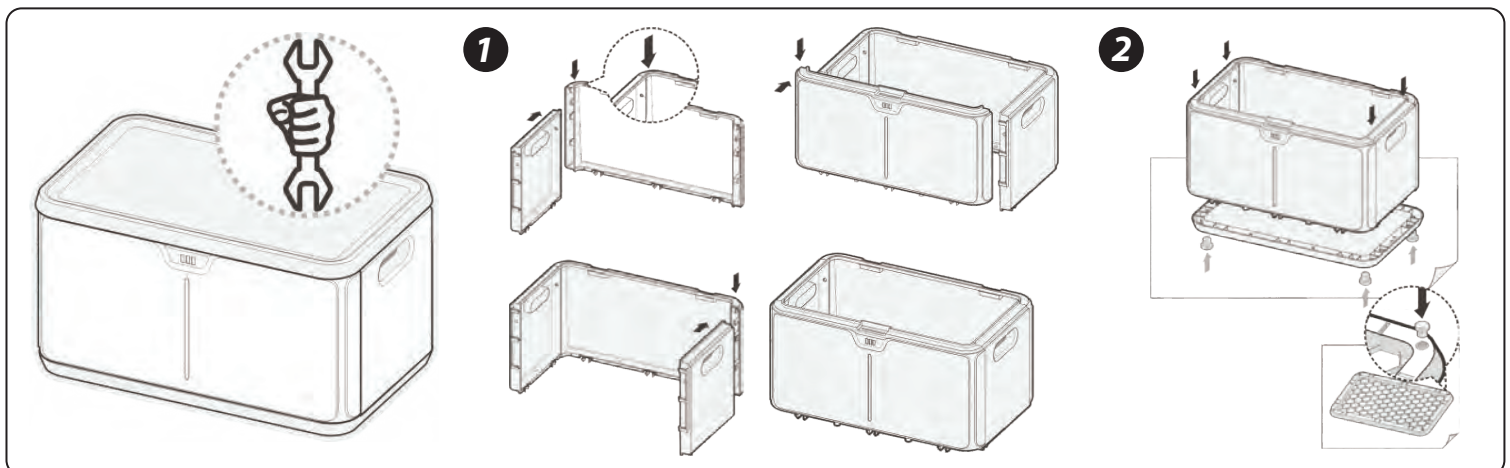
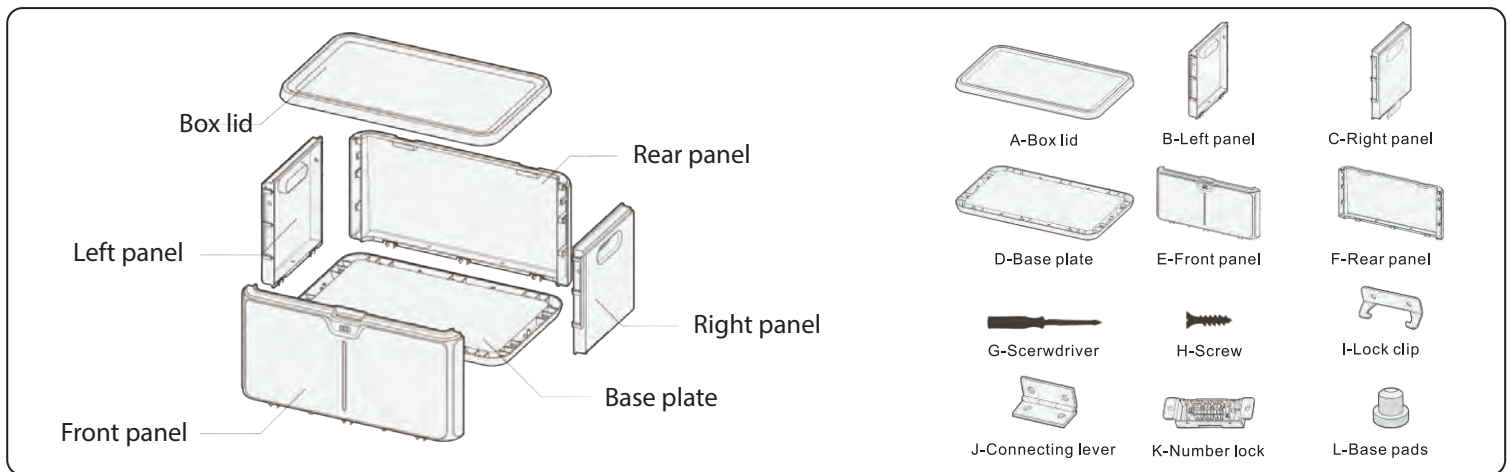

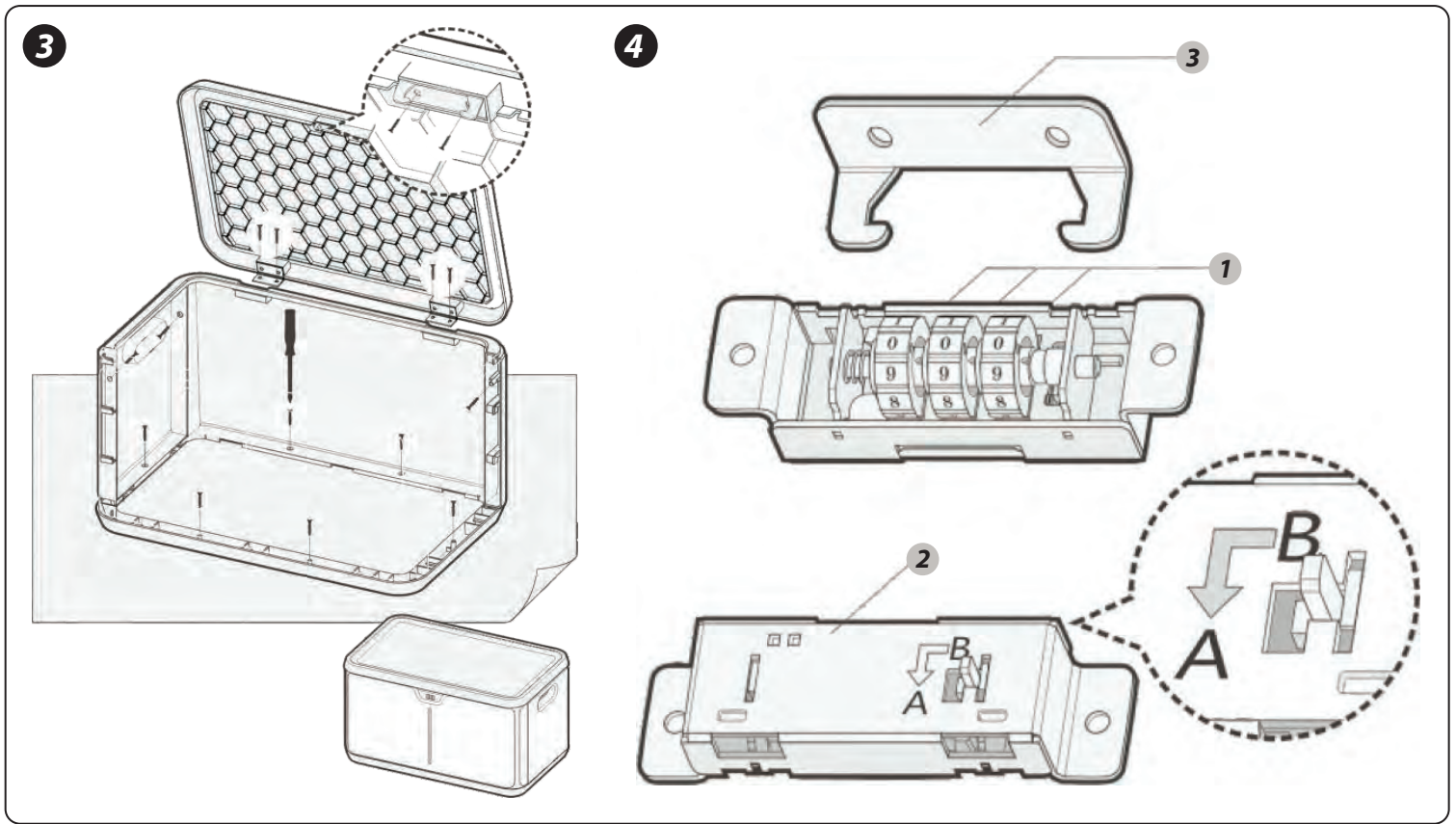

HOW TO SET A CUSTOM PASS CODE:

1. Adjust the pin to your current pass code (By default, the lock pin is set to "0000").

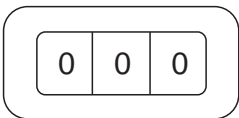

2. Completely remove the top drawer from the cabinet and on the inside of the cabinet switch the lever located on the lock from the B to A position.

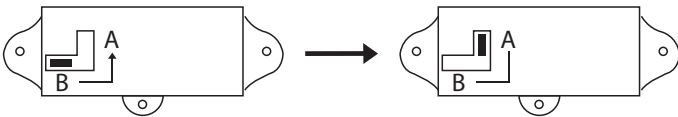

3. While lever is in A position - set the desired new code. Make sure the 4 dials you set are exactly parallel and lined up - you don't want to set to the wrong number by mistake. (Sample below).

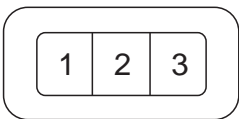

4. Once your new pass code is entered, change the lever back from A to the B position.

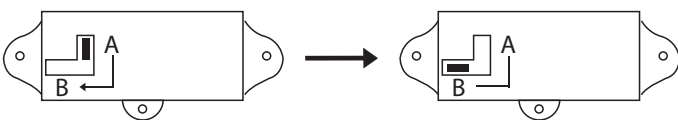

5. Make sure to write down & remember your code.
There is no way to recover it once it is set.

Questions? Comments?
We are here to help!
Phone: (1) 718-535-1800
Email: support@pyleusa.com

California Prop 65 Warning
⚠️WARNING:
This product contains Phthalates which is known to the state of California to cause cancer birth defects and other reproductive harm. Do not ingest.
For more info go to: www.P65warnings.ca.gov