

**SQDBT30** RHEA XXX

## 32 lbs. Neoprene Coated Dumbbell Set with Stand

Colour Grey, Black and Orange All Purpose  
Hand Weight Anti-Slip Hex Shape Dumbbell



### USER GUIDE

DOWNLOAD THE SQUATZ APP TO FOLLOW YOUR CUSTOM SQUATZ WORKOUT!  
ALL SQUATZ PRODUCTS COME WITH AN ADVANCED WORKOUT PROGRAM!

#### Assembly Instructions

- Set up the side panels. Insert the connecting tubes (5x) into the holes of the side panels.
- Secure the connecting tubes and side panels with the screws.
- Place the dumbbells on the assembled stand.

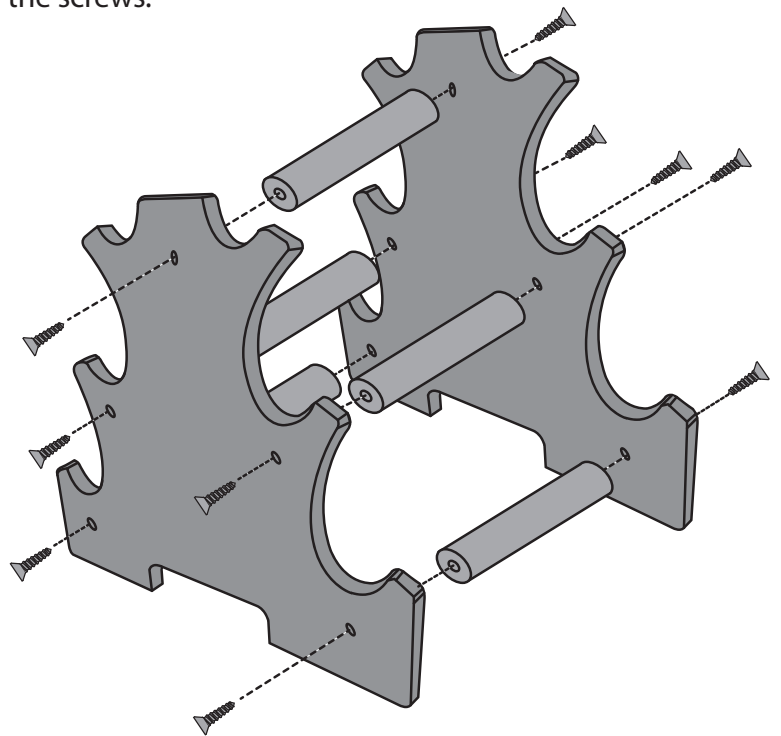
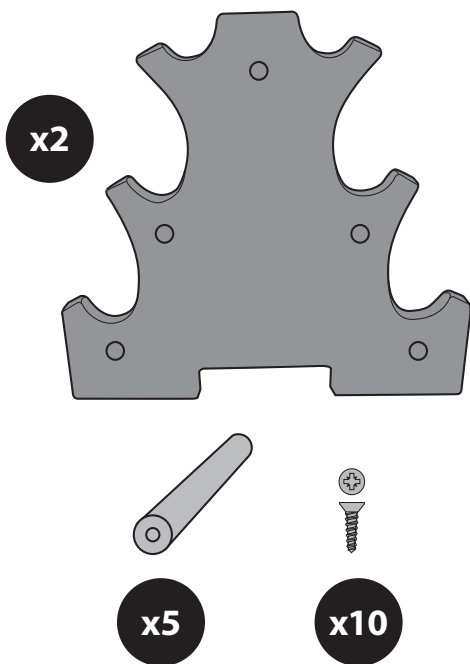

#### Features:

- 3 Pairs of Dumbbells
- Anti-Slip and Anti-Roll
- Ideal for Resistance and Trainings
- Durable, Neoprene Material Coated Cast Iron
- Easy to Assemble
- Weight Rack and Assembly Tools Included
- Contoured Handles

#### What's in the Box:

- (2) 3 lbs. Gray Dumbbell
- (2) 5 lbs. Black Dumbbell
- (2) 8 lbs. Orange Dumbbell
- (1) Dumbbell Stand with Screws

#### Technical Specs:

- Construction Material: Cast Iron with Neoprene Coating
- Weight Capacity: 3 lbs. Gray, 5 lbs. Black, 8 lbs. Orange
- 3 lbs. Size: 5.83" x 2.4" x 2.4" -inches
- 5 lbs. Size: 6.5" x 3.15" x 3.15" -inches
- 8 lbs. Size: 7.5" x 3.5" x 3.5" -inches



#### Questions? Comments?

We are here to help!

Phone: (1) 718-535-1800

Email: [support@pyleusa.com](mailto:support@pyleusa.com)